



our **power**, your **passion**

EN



Product Catalogue 2019





Symbols

Contents

	<p>EHS (Ergonomic Handling System) System adopted for the controls of several power tools, to ensure easy use, reduced fatigue, and the utmost simplification for users.</p>
	<p>Gasoline Gasoline fuel type engine.</p>
	<p>Diesel Diesel fuel type engine.</p>
	<p>Original accessories and spare parts Quality mark identifying original Emak parts and accessories. Designed to the most stringent quality standards, these items guarantee smoother operation of the machine and longer service life.</p>

	Corporate setup	4	
	Rotary tillers	8	
	Two wheel tractors	20	
	Flail mowers	56	
	Cutterbar mowers	62	
	Transporters	86	



Our Vision

"Innovative solutions for the best customer value"

We aim to operate as one of the world's foremost players in the development, production and distribution of machines, components and accessories for gardening, agriculture, forestry and industry, with an offering of innovative products and services designed to make the work of our clients in the consumer and professional markets efficient and enjoyable, guaranteeing that they always receive the highest possible value.



Structure

The **Emak Group** is active in the development, production and worldwide sale of an extensive range of products for three business segments:

Outdoor Power Equipment

- products for gardening, forestry and agriculture, including brushcutters, lawnmowers, garden tractors, chainsaws, rotary tillers and rotary cultivators.

Pumps and High Pressure Water Jetting

- products for agriculture, including centrifugal and diaphragm pumps for crop spraying and weed control;
- products for industry, including pumps for industrial applications and high and very-high pressure systems;
- products for cleaning, namely professional and semiprofessional high-pressure washers, floor scrubber-dryers and vacuum sweepers.

Components and Accessories

- products such as trimmer line and line heads for brushcutters, accessories for chainsaws, guns, valves and nozzles for high-pressure washers and for agricultural applications, plus precision farming products (sensors and computers).

The group has approximately **2,000 employees** overall and generates annual sales of more than **EUR 400 million**.



The Emak Group

Divisions and Product Range

Outdoor Power Equipment

Product range

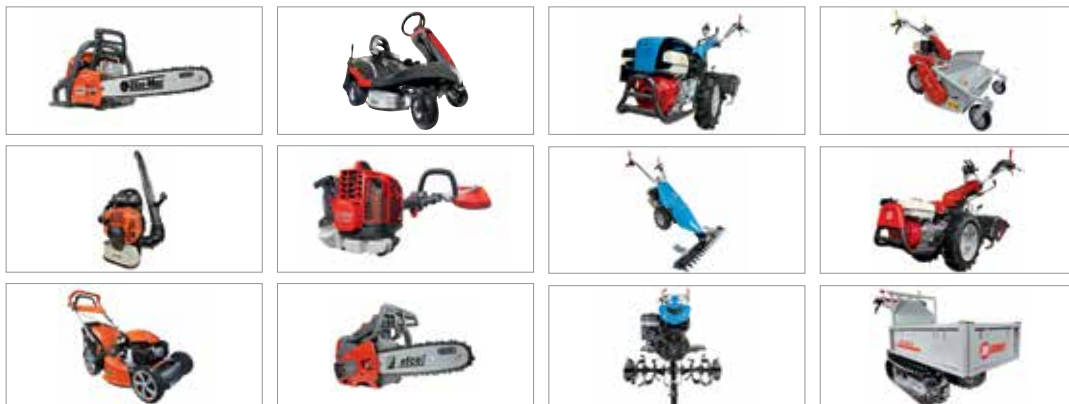

Pumps and High Pressure Water Jetting

Product range



Components and Accessories

Product range

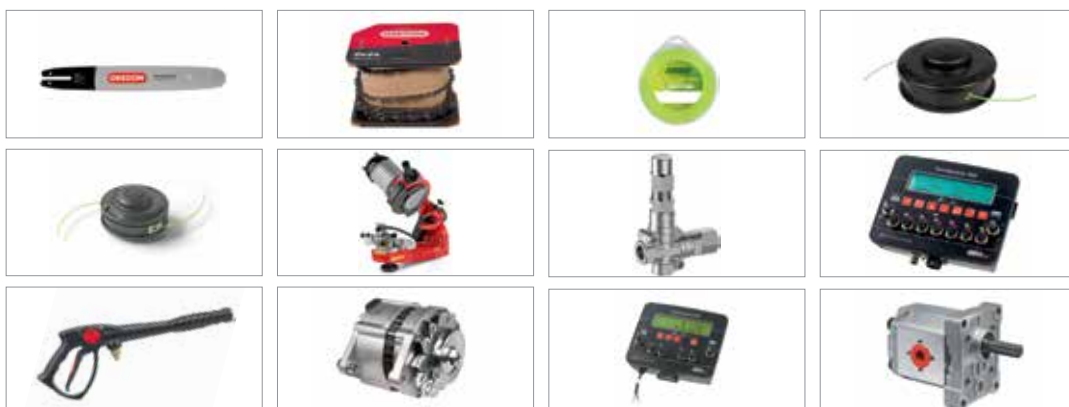

Our Passion

Emak's green ethos is made up of **certainty**, **innovation** and **completeness**. Our green credentials are based on **care**, **respect**, **passion** and **design focus**. That's why, with our **Efco**, **Oleo-Mac**, **Bertolini** and **Nibbi** brands, **Emak** stands as a benchmark in groundcare and garden maintenance for professionals and amateurs alike. A **passion** that has been **all-Italian** for more than 50 years. There's an **Emak** for everyone.



Structure

Emak operates in the **Outdoor Power Equipment** segment through **10** companies engaged in the development, production and sale of **products for gardening and forestry, and small agricultural machines**, including brushcutters, lawnmowers, garden tractors, chainsaws, rotary tillers and rotary cultivators.

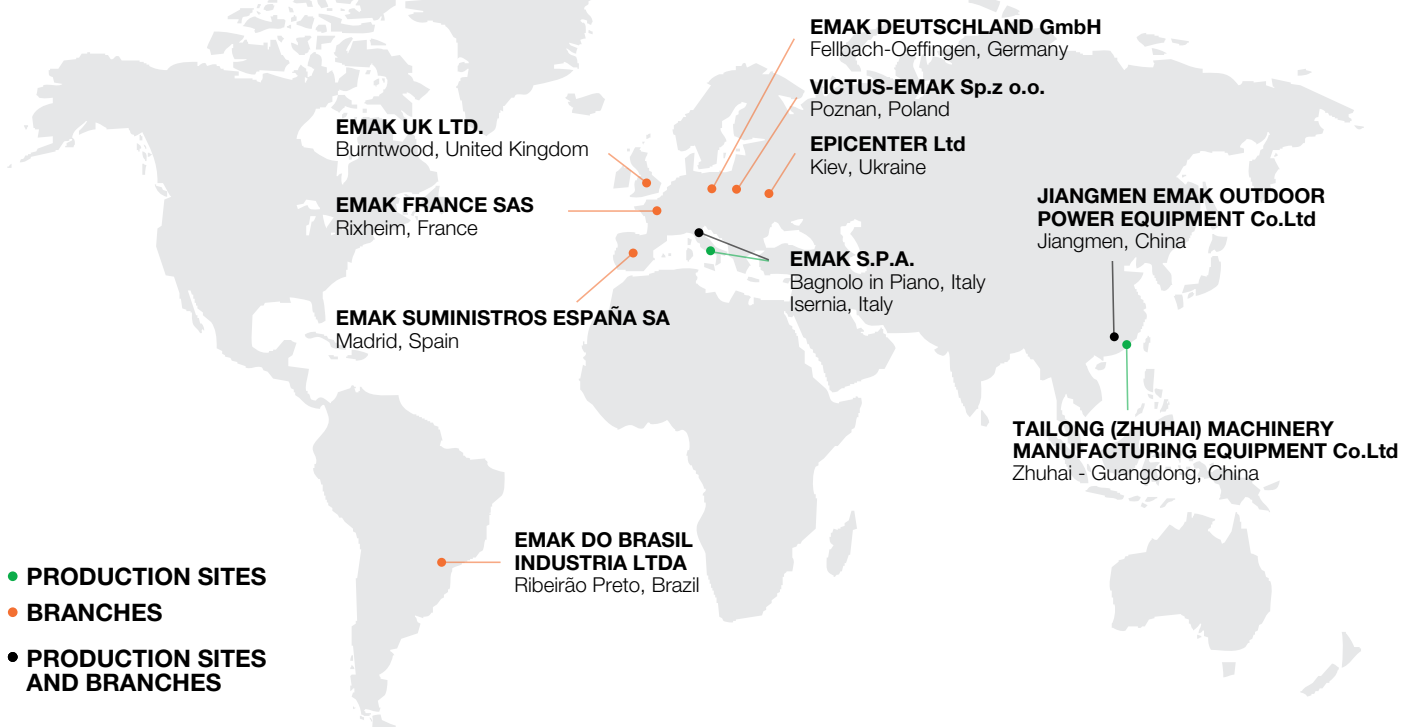

Facts and Figures

4	brands
4	production units
8	foreign sales branches
~800	personnel
~170	€ mln sales
150	distributors
115	countries served
22	product families
250	models



Outdoor Power Equipment

Certifications

Yes, we care.

We were the world's first company in our field to obtain certifications in three crucial areas of business sustainability:

- **Ethics**
- **Environment**
- **Quality**

We care

Certified Quality Ethics Environment

Products and Accessories Range

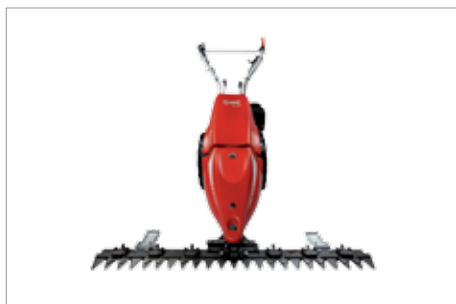

A thorough-going process of product development implemented by Nibbi has resulted in a **truly comprehensive, constantly updated range of machines, suitable for agriculture ground care and maintenance of allotments and gardens** and capable of responding to the needs of users at every level. Products differ according to the use for which they are designed, but all feature the same high standards of quality in terms of performance, reliability, comfort and safety.

Home-plus



Home-plus

A range of machines aimed at the home user, for tidying and cleaning the garden, cutting hedges and small trunks or stems, and DIY jobs in general. Characterized by lightweight and compact construction, to make the task of the operator that much simpler. Easy to start, easy to use, easy to maintain: these are the ideal tools for getting things done quickly and neatly around the home.

Tough-tech



Tough-tech

Solid and dependable, these are machines designed for heavy and frequent use in countryside environments: clearing overgrown and uncultivated areas, pruning and cutting firewood, crop irrigation and disinfection tasks. Designed adopting solutions certain to ensure high work rates and maximum durability over time.

Sharp-pro



Sharp-pro

No-nonsense everyday tools for the busy professional, these are machines that stand out for the toughness of their components, their high performance and their matchless long-term durability. Specific materials used in construction guarantee unwavering quality even when tackling the most severe and lengthy of tasks, like forestry work and the clearance of uncultivated areas or scrub and undergrowth.

Specialist machines for soil preparation.
Powerful and sturdy over large areas,
practical and reliable even in private gardens
and allotments: a wide range
to suit all needs.



Rotary tillers

HOME



010



INTENSIVE



105 S

NEW



PROFESSIONAL



118

NEW



055

NEW



095 S

NEW



TECHNICAL DATA



gearbox



power



rotor

Rotary tiller for home use

010



Ideal for small plots requiring periodic maintenance and a variety of jobs such as preparing soil for seeding grass, digging furrows for planting, and other operations such as turf scarification and path tidying.



Folding handlebars for easy storage and transport (e.g. in the boot of a car).



Spur gear and worm gear drive protected by robust aluminium housing for maximum resistance to impact (stones, low walls, fences) and operating stresses.



The front engine guard enables the machine to be rested upright in the garage or tool shed, saving considerable space.

010

Power supply	Engine	Model	Displacement	Power	Starting	Code
gasoline	POWERED by HONDA	GX 25 OHV	25 cm ³	0.8 HP	recoil start	68609130E5

Focus on accessories



Roller brush
Code **68602002**

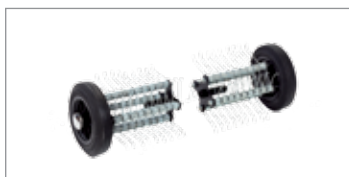

Scarifier
Code **68602003**



Plough
Code **68602004**



Gearbox:

1-speed (1 forward)

Rotor speed with engine at 3600 rpm

162

Dimensions (mm)

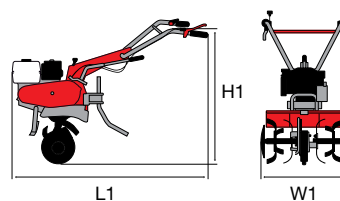

L1	1250
H1	1000
W1	300

Transmission	worm gear drive in aluminium housing
Clutch	centrifugal
Handlebars	reversible
Rotor	30 cm
Power take-off	no
Spur	yes
Towing hitch	no
Transport wheel	yes
Weight	14 kg

Rotary tiller for home use

055

NEW



Ideal for home gardeners who need to prepare vegetable patches and flower beds for seeding, this model offers an excellent combination of manageability and user-friendliness.



Rear wheel for easy transportation of the machine.



Speed regulator with integrated on-off system and control lever located within easy reach.



46 cm rotor with three elements per side, can be reduced to 32-22 cm.

055

Power supply	Engine	Model	Displacement	Power	Starting	Code
gasoline	Emak	K 300 H OHV	80 cm ³	2.4 HP	recoil start	68569002E5



Gearbox:
1-speed (1 forward)

Rotor speed with engine at 3400 rpm

159

Dimensions (mm)

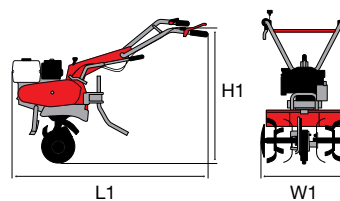

L1	1150
H1	1000
W1	460-320-220

Transmission	chain
Clutch	belt with tensioner
Handlebars	3 vertical adjustment positions
Rotor	46 cm, can be reduced to 32-22 cm
Power take-off	no
Spur	yes
Towing hitch	no
Transport wheel	yes
Weight	27 kg

Rotary tiller for home use

095 S

NEW



Ideal for home gardeners who need to soften up the soil for seeding, this model offers an excellent combination of manageability and user-friendliness.



Front wheel for easy transportation of the machine. The wheel can be easily folded upward without tools to facilitate operations on the ground.

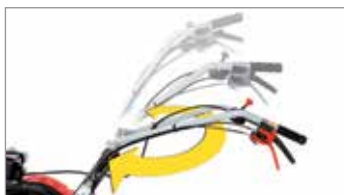

Handlebars with horizontal and vertical adjustment to allow the operator to assume the correct posture while working.



82 cm rotor with three elements per side with lateral protection discs.

095 S

Power supply	Engine	Model	Displacement	Power	Starting	Code
gasoline	Emak	K 800 HT OHV	182 cm ³	5.7 HP	recoil start	68599002E5

Focus on accessories



Furrowing tool
Code **69209081**
(requires tool holder
69209087)



Plough
Code **69209082**
(requires tool holder
69209087)



Potato digger
Code **69209083**
(requires tool holder
69209087)



Tool holder
Code **69209087**

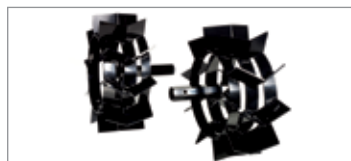

Pair of metal wheels
Code **69209084**



Gearbox:

2-speed (1 forward + 1 reverse)

Rotor speed with engine at 3400 rpm

159 **1** **1R** 66

Dimensions (mm)

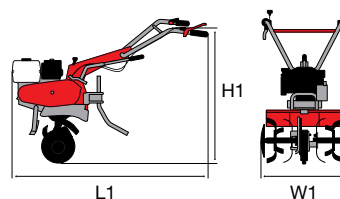

L1	1400
H1	800
W1	820-550

Transmission	chain
Clutch	belt with tensioner
Handlebars	with vertical and horizontal adjustment
Rotor	82 cm, can be reduced to 55 cm, with lateral protection discs
Power take-off	no
Spur	yes
Towing hitch	yes
Transport wheel	yes
Weight	57 kg

Rotary tiller for intensive use

105 S

NEW



Ideal for demanding home gardeners to prepare the soil for sowing. This model features two forward speeds and one reverse, the perfect combination for the most difficult jobs.



Practical and ergonomic external gear selector. Integrated tool holder and depth adjustable jackleg.



Handlebars with vertical and horizontal adjustment by means of an easily accessible lever, allowing the operator to assume the correct posture for the maximum working comfort.









85 cm rotor (reducible to 60-35 cm), oversized knives and lateral protection discs.

105 S

Power supply	Engine	Model	Displacement	Power	Starting	Code
gasoline	Emak	K 800 HC OHV	182 cm ³	5.7 HP	recoil start	68589011E5

Focus on accessories

	Furrowing tool Code 69209081
	Plough Code 69209082
	Potato digger Code 69209083
	Pair of metal wheels Code 69209116
	Pair of tyred wheels 3.50-6\" Code 69209089
	Pair of tyred wheels 3.50-8\" Code 69209114



Gearbox:

3-speed (2 forward + 1 reverse)

Rotor speed with engine at 3400 rpm

83	1	1R	62
114	2		

Dimensions (mm)

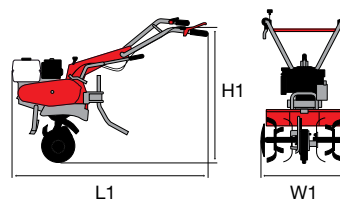

L1	1630
H1	1050
W1	850-600-350

Transmission	with oil-bath gearbox and chain
Clutch	belt with tensioner
Handlebars	with vertical and horizontal adjustment
Rotor	85 cm, reducible to 60-35 cm, with side protection discs
Power take-off	no
Spur	yes, depth adjustable
Towing hitch	yes, with integral tool holder
Transport wheel	yes
Weight	63 kg

Professional rotary tiller

118

NEW



Model designed to meet the needs of smallholders and groundcare professionals. The direct gear transmission on the crankshaft makes the tool resistant to the stresses generated when working on hard terrain.



Direct gear transmission on crankshaft.



Extreme versatility thanks to the 4-speed gearbox (3 forward + 1 reverse) that makes it possible to achieve the same tillage results irrespective of the hardness and consistency of the soil.

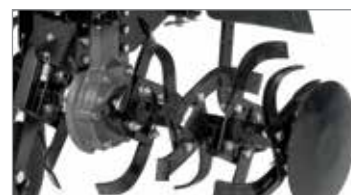

Oil-bath gear drive, extremely robust and with reduced maintenance requirements.

118

Power supply	Engine	Model	Displacement	Power	Starting	Code
gasoline	Emak	K 900 HR OHV	252 cm ³	7.0 HP	recoil start	68579001E5S2
diesel	Emak	K 7000 HDR	349 cm ³	6.3 HP	recoil start	68579002E5S2

Focus on accessories



Furrowing tool
Code 69209081



Plough
Code 69209082



Potato digger
Code 69209083



Pair of metal wheels
Code 69209122



Pair of tyred wheels
3.50-8"
Code 69209123



Gearbox:

4-speed (3 forward + 1 reverse)

Rotor speed with engine at 3600 rpm

58	1	1R	44
102	2		
140	3		

Dimensions (mm)

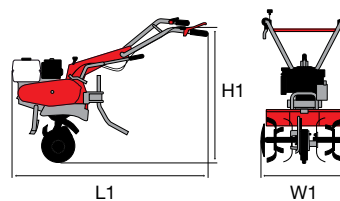

L1	1500 (gasoline) 1700 (diesel)
H1	1100
W1	1000-820-600

Transmission	with oil-bath gearbox
Clutch	wet multi-disc
Handlebars	with vertical and horizontal adjustment
Rotor	100 cm, reducible to 80-60 cm, with side protection discs
Power take-off	yes, 3600 rpm
Spur	yes, depth adjustable
Towing hitch	yes, with integral tool holder
Transport wheel	yes (diesel version with front stand)
Weight	96 kg with petrol engine – 131 kg with diesel engine

Powerful and reliable,
easy to handle, reversible and versatile,
these machines represent
the ideal solution for all ground jobs
in any season.



Two wheel tractors

HOME



BRIK



BRIK 1 S



INTENSIVE



BRIK 5 S



KAM 7 S



KAM 13 S



PROFESSIONAL



MAK 17 S



MAK 18 S



TECHNICAL DATA



gearbox



brakes



power



differential block



reverse gear



half-shafts with reduction gears

OPTIONAL



rotor



brush



plough



turbine



flail mower



mower



shovel



cutter bar



trailer

Two wheel tractor for home use

BRIK



Ideal for home users with small gardens requiring periodic soil preparation for sowing, also in particularly difficult conditions. The rotor turns in the opposite direction to the direction of rotation of the wheels, thus giving the operator the maximum control of the cultivator and significantly reducing transmitted vibration levels.



50 cm wide counter-rotating rotor to facilitate work on particularly difficult terrain.



Large sized wheels for easier maneuvering of the machine.



Rotor depth adjustment enables operation on all types of terrain.

BRIK

Power supply	Engine	Model	Displacement	Power	Starting	Code
gasoline	Emak	K 700 H OHV	182 cm ³	5.4 HP	recoil start	68369002E5

Focus on accessories



Rear-mounted furrowing tool
Code 69209111



Pair of steel wheels Ø 370 mm
Code L0051200



WITH TWO WHEEL TRACTOR

Gearbox/ Speed (km/h):

2-speed (1 forward + 1 reverse) with 4.00-8" wheels

Speed (km/h)

1.45 **1** **1R** 2.64

Dimensions (mm)

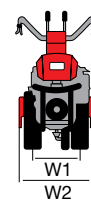
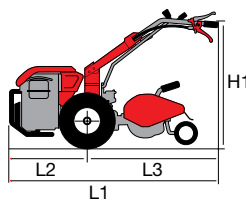

L1	1650
L2	540
L3	1110
H1	960
W1	430
W2	500

Transmission	with oil-bath gearbox
Clutch	direct engagement
Handlebars	with vertical adjustment
Reverse gear	no
Differential	no
Brakes	no
Power take-off	synchronised with forward travel
Accessories installation	no
Towing hitch	no
Cowling	no
Weight	75 kg (complete machine)

Two wheel tractor for home use

BRIK 1 S



Designed for demanding home gardeners tending an allotment or vegetable plot, this two wheel tractor is extremely functional and offers the optimal combination of ease of use and safety.



Handlebar-mounted PTO control.



Handlebars with vertical and horizontal adjustment and 180° reversible, with vibration-damping device to assure more comfortable handling.



Integral QuickFit coupling that allows the operator to change the tools without using tools.

BRIK 1 S

Power supply	Engine	Model	Displacement	Power	Starting	Code
gasoline	POWERED BY HONDA	GX 160 OHV	163 cm ³	4.8 HP	recoil start	68319103E5
gasoline	Emak	K 800 H OHV	182 cm ³	5.7 HP	recoil start	68319105E5

Accessories









BRIK 1 S

Accessory		Optional accessory		
Rotors				
 <p>Rotor Ø 280, 50-(35) cm 12 spikes coupling for Quickfit (can be reduced to 35 cm with kit L0116300)</p>	69219111		Support wheel	Z0020368
			Rear-mounted furrowing tool	L0050600
 <p>Rotor Ø 280, 60-50-(35) cm 16 spikes coupling for Quickfit (can be reduced to 35 cm with kit L0116300)</p>	69219108		Support wheel	Z0020368
			Rear-mounted furrowing tool	L0050600
Tyred wheels				
 <p>Pair of tyred wheels 4.00x8" Fixed disc Quickfit coupling</p>	69209020A		Pair of snow chains	L1055015
			Pair of spacers W 100 mm	69209096
Steel wheels				
 <p>Pair of steel wheels Ø 370 mm</p>	L0051200			



Accessories

Accessory		Optional accessory			
Towing hitch					
	Towing hitch	L0060900			
Adjustable tool holder					
	Adjustable tool holder (requires towing hitch L0060900)	L0103400		Single share plough	L0100000
				Furrowing tool	L0103200
Bar drive					
	Cam drive	69229092		0.92 m Complete central cutter plate Special teeth	69222011
Front brush					
	Brush W 80-Ø 35 cm With horizontal and vertical adjustment	L0070000			

Two wheel tractor for intensive use

BRIK 5 S



Designed for small and medium-size plots, this machine very effectively combines professional level reliability and performance with extreme ease of handling, making it ideal for demanding home users and smallholders. The full range of accessories, including rotors, cutterbars, brushes and snowthrowers, are designed to meet the requirements of users seeking a multifunction machine that's both practical and safe.



Handlebars with vertical and horizontal adjustment and 180° reversible, with vibration-damping device to assure more comfortable handling.



The EHS system ensures ease of use, reduced effort and the maximum simplification for users.



Practical forward/reverse shuttle enables the operator to change quickly into reverse gear from any speed, making the machine easy to handle even with the rotor or other accessories mounted.

BRIK 5 S

Power supply	Engine	Model	Displacement	Power	Starting	Code
gasoline	POWERED BY HONDA	GX 200 OHV	196 cm ³	5.8 HP	recoil start	68359008E5
gasoline	Emak	K 800 H OHV	182 cm ³	5.7 HP	recoil start	68359009E5
diesel	Emak	K 7000 HD	349 cm ³	6.7 HP	recoil start	68359017E5

Focus on accessories



Rotor Ø 280, 60-50-(40) cm
16 spikes
Fixed coupling
(can be reduced to 40 cm with kit **69210259**)
Code **69219102**



Oil-immersed drive
Code **69229097A**



Front shovel W 100x40 cm
Quickfit coupling
With horizontal and vertical adjustment
(requires QuickFit **69212006**)
Code **69209065**



WITH TWO WHEEL TRACTOR

Gearbox/ Speed (km/h):

4-speed (2 forward + 2 reverse) with 4.00-8" wheels

Speed (km/h)	1.05	1	1R	1.11
	2.20	2	2R	2.32

Dimensions (mm)

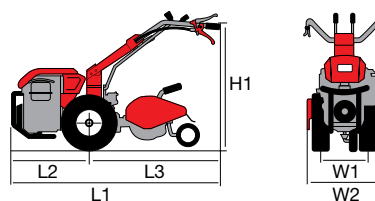

L1	1740
L2	550
L3	1190
H1	1250-300
W1	370
W2	600-400

WITH CUTTERBAR MOWER

Gearbox/ Speed (km/h):

4-speed (2 forward + 2 reverse) with 4.00-8" wheels

Speed (km/h)	1.11	1	1R	1.05
	2.32	2	2R	2.20

Dimensions (mm)

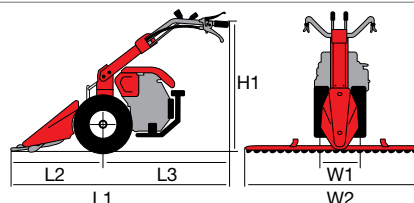

L1	1670
L2	900
L3	770
H1	1250-300
W1	370
W2	1270-950

Transmission	with oil-bath gearbox
Clutch	dry multidisc
Handlebars	with vertical and horizontal adjustment and 180° reversible, with vibration-damping device
Reverse gear	yes, with handlebar lever
Differential	no
Brakes	no (yes, only in diesel engine version)
Power take-off	independent 973 rpm
Accessories installation	QuickFit (optional)
Towing hitch	optional
Cowling	no
Weight	116 kg (with engine, rotor and wheels)



















Accessories



BRIK 5 S

Accessory		Optional accessory			
Rotors					
	Rotor Ø 280, 60-50-(40) cm 16 spikes Fixed coupling (can be reduced to 40 cm with kit 69210259)	69219102		Support wheel	Z0020368
				Rear-mounted furrowing tool	L0009800
	Rotor Ø 280, 60-50-(40) cm 16 spikes Quickfit included (can be reduced to 40 cm with kit 69210259)	69219088		Support wheel	Z0020368
				Rear-mounted furrowing tool	L0009800
Front ballast kit					
	Front ballast 7.8 Kg	69209118			
Tyred wheels					
	Pair of tyred wheels 4.00x8" Fixed disc	69209025B		Screw-adjustable half-shafts	69209105
				5-hole adjustable half-shafts	L0059500
				Pair of spacers W 50 mm	69209094
				Pair of snow chains	L1055015
	Pair of tyred wheels 4.00x10" Fixed disc	69200024A		Screw-adjustable half-shafts	69209105
				5-hole adjustable half-shafts	L0059500
				Pair of spacers W 50 mm	69209094
				Pair of snow chains	L0021600
	Pair of tyred wheels 4.00x10" Adjustable disc	69209004B		Pair of 15 kg ballasts (not compatible with adjustable half-shafts)	69209099
				Pair of 15 kg ballasts (compatible with adjustable half-shafts)	69209075
				Screw-adjustable half-shafts	69209105
				5-hole adjustable half-shafts	L0059500
				Pair of spacers W 50 mm	69209094
				Pair of snow chains	L0021600
	Pair of tyred wheels 16-6.50x8" Fixed disc	69209012A		Screw-adjustable half-shafts	69209105
				5-hole adjustable half-shafts	L0059500

Accessories

Accessory		Optional accessory		
Steel wheels				
 <p>Pair of steel wheels Ø 480x100 mm</p>	69209067		Pair of width adjustment rings W 100 mm	L0040100
			Screw-adjustable half-shafts	69209105
			5-hole adjustable half-shafts	L0059500
			Pair of spacers W 50 mm	69209094
Towing hitch				
	Towing hitch	69209072		
Drives and Cutter plates				
 <p>Oil-immersed drive</p>	69229097A		0.95 m Complete central cutter plate Semi-fine teeth	69229084*
			1.15 m Complete central cutter plate Semi-fine teeth	69229085*
			1.27 m Complete central cutter plate Semi-fine teeth	69229086*
			0.95 m Complete central cutter plate Special teeth Side protection discs	69229068A
			1.15 m Complete central cutter plate Special teeth Side protection discs	69229069A
			1.27 m Complete central cutter plate Special teeth Side protection discs	69229070A
			1.22 m Complete central cutter plate " UNIVERSAL " ESM (requires kit L0058900)	69229036
			1.02 m Complete central cutter plate " KOMUNAL " ESM (requires kit L0058900)	L0066900
			1.22 m Complete central cutter plate " KOMUNAL " ESM (requires kit L0058900)	69229037
			Ballast for oil-immersed drive	L0105700
			Directional guides for semi-fine tooth cutter plate	69229098

* (recommended for use in conjunction with directional guides 69229098).

Accessories



BRIK 5 S

Accessory		Optional accessory		
Adjustable tool holder				
	Adjustable tool holder (requires towing hitch 69209072)	L1055001A		Single share plough Z0020102
				Furrowing tool Z0020133
				Potato digger L0066400
QuickFit				
	QuickFit coupling	69212006		
Front shovel				
	Front shovel W 100x40 cm Quickfit coupling With horizontal and vertical adjustment (requires QuickFit 69212006)	69209065		
Snow thrower				
	Turbine W 60 cm Two stages Adjustable ejector chute Quickfit coupling (requires QuickFit 69212006)	L0026200		
Front brush				
	Brush W 100xØ 35 cm With horizontal and vertical adjustment Quickfit coupling (requires QuickFit 69212006)	L0094200		
Rotor type flail mower				
	Flail mower W 50 cm 16 'Y' shaped knives Integral safety brake Adjustable flange Adjustable support roller PTO right-hand rotation Quickfit coupling (requires QuickFit 69212006)	69209119		
Mower				
	Mower W 65 cm Single blade Integral safety brake Adjustable and removable swivel wheels Adjustable lateral skids PTO right-hand rotation Quickfit coupling (requires QuickFit 69212006)	69209008		



Two wheel tractor for intensive use

KAM 7 S



Thanks to the differential with locking lever on the handlebars, which affords perfect manoeuvrability and grip even on the most difficult terrain and on slopes, the key strength of this machine is its ease of use. The facility to use a range of different accessories for tillage, grass cutting and maintenance of gardens or urban spaces makes these machines exceptionally versatile and perfectly adapted to meet the needs of demanding home users and smallholders.



Ergonomically positioned easy action levers for differential locking and reverse shuttle.



Independent brakes on each wheel and handlebar steering to facilitate travel on even the most difficult terrain.



QuickFit coupling that allows the operator to change the tools without using tools.

KAM 7 S

Power supply	Engine	Model	Displacement	Power	Starting	Code
gasoline	POWERED by HONDA	GX 200 OHV	196 cm ³	5.8 HP	recoil start	68359102E5
gasoline	POWERED by HONDA	GX 270 OHV	270 cm ³	8.4 HP	recoil start	68359118E5
gasoline	Emak	K 800 H OHV	182 cm ³	5.7 HP	recoil start	68359106E5
gasoline	Emak	K 900 H OHV	252 cm ³	7.0 HP	recoil start	68359120E5
gasoline	KOHLER	CH 270 OHV	208 cm ³	7.0 HP	recoil start	68359107E5
diesel	Emak	K 7000 HD	349 cm ³	6.7 HP	recoil start	68359115E5

Focus on accessories



Rotor Ø 280, 60-50-(40) cm
16 spikes
Quickfit included
(can be reduced to 40 cm
with kit **69210259**)
Code **69219088**



Turbine W 60 cm
Two stages
Adjustable ejector chute
Quickfit coupling
(requires QuickFit **69212006**)
Code **L0026200**



Flail mower W 65 cm
24 'Y' shaped knives
Integral safety brake
Adjustable flange
Adjustable support roller
PTO right-hand rotation
Quickfit coupling
(requires QuickFit **69212006**)
Code **L0091000**



WITH TWO WHEEL TRACTOR

Gearbox/ Speed (km/h):

4-speed (2 forward + 2 reverse) with 4.00-10" wheels

Speed (km/h)	1.20	1	1R	1.27
	2.52	2	2R	2.66

Dimensions (mm)

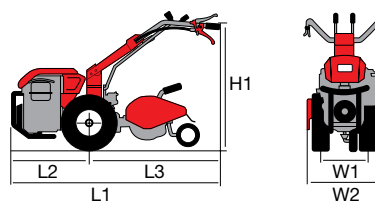

L1	1780
L2	570
L3	1210
H1	1340-470
W1	370
W2	700-400

WITH CUTTERBAR MOWER

Gearbox/ Speed (km/h):

4-speed (2 forward + 2 reverse) with 4.00-10" wheels

Speed (km/h)	1.27	1	1R	1.20
	2.66	2	2R	2.52

Dimensions (mm)

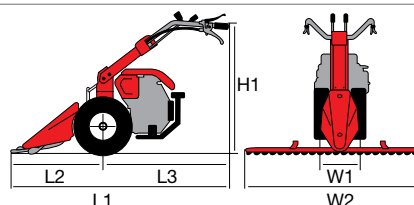











L1	1690
L2	900
L3	790
H1	1440-620
W1	370
W2	1420-950

Transmission	with oil-bath gearbox
Clutch	dry multidisc
Handlebars	with vertical and horizontal adjustment and 180° reversible, with vibration-damping device
Reverse gear	yes, with handlebar lever
Differential	yes
Brakes	yes
Power take-off	independent 973 rpm
Accessories installation	QuickFit (optional)
Towing hitch	yes
Cowling	no
Weight	120 kg (with engine, rotor and wheels)

Accessories



KAM 7 S

Accessory	Optional accessory
 <p>Rotor Ø 280, 60-50-(40) cm 16 spikes Fixed coupling (can be reduced to 40 cm with kit 69210259)</p>	 Support wheel Z0020368  Rear-mounted furrowing tool L0009800
 <p>Rotor Ø 280, 60-50-(40) cm 16 spikes Quickfit included (can be reduced to 40 cm with kit 69210259)</p>	 Support wheel Z0020368  Rear-mounted furrowing tool L0009800
 <p>Rotor Ø 320, (80)-70-60-(50) cm 20 spikes Quickfit included Support wheel included (expandable to 80 cm with kit 69210231) (can be reduced to 50 cm with kit 69210229)</p>	 Rear-mounted furrowing tool L0009800
 <p>Rotor Ø 320, (80)-70-60-(50) cm 20 spikes Fixed coupling Support wheel included (expandable to 80 cm with kit 69210231) (can be reduced to 50 cm with kit 69210229)</p>	 Rear-mounted furrowing tool L0009800

Accessories

Accessory		Optional accessory		
Tyred wheels				
 <p>Pair of tyred wheels 4.00x8" Fixed disc</p>	69209025B	 <p>Screw-adjustable half-shafts</p>	69209105	
		 <p>5-hole adjustable half-shafts</p>	L0059500	
		 <p>Pair of spacers W 50 mm</p>	69209094	
		 <p>Pair of snow chains</p>	L1055015	
 <p>Pair of tyred wheels 4.00x10" Fixed disc</p>	69200024A	 <p>Screw-adjustable half-shafts</p>	69209105	
		 <p>5-hole adjustable half-shafts</p>	L0059500	
		 <p>Pair of spacers W 50 mm</p>	69209094	
		 <p>Pair of snow chains</p>	L0021600	
 <p>Pair of tyred wheels 4.00x10" Adjustable disc</p>	69209004B	 <p>Pair of 15 kg ballasts (not compatible with adjustable half-shafts)</p>	69209099	
		 <p>Pair of 15 kg ballasts (compatible with adjustable half-shafts)</p>	69209075	
		 <p>Screw-adjustable half-shafts</p>	69209105	
		 <p>5-hole adjustable half-shafts</p>	L0059500	
		 <p>Pair of spacers W 50 mm</p>	69209094	
		 <p>Pair of snow chains</p>	L0021600	
 <p>Pair of tyred wheels 5.00x10" Adjustable disc</p>	69209003B	 <p>Pair of 15 kg ballasts (not compatible with adjustable half-shafts)</p>	69209099	
		 <p>Pair of 15 kg ballasts (compatible with adjustable half-shafts)</p>	69209075	
		 <p>Screw-adjustable half-shafts</p>	69209105	
		 <p>5-hole adjustable half-shafts</p>	L0059500	
		 <p>Pair of spacers W 50 mm</p>	69209094	
		 <p>Pair of snow chains</p>	L0030200	
 <p>Pair of tyred wheels 16-6.50x8" Fixed disc</p>	69209012A	 <p>Screw-adjustable half-shafts</p>	69209105	
		 <p>5-hole adjustable half-shafts</p>	L0059500	

Accessories



KAM 7 S

Accessory		Optional accessory		
Steel wheels				
 <p>Pair of steel wheels Ø 480x100 mm</p>	69209067		Pair of width adjustment rings W 100 mm	L0040100
			Screw-adjustable half-shafts	69209105
			5-hole adjustable half-shafts	L0059500
			Pair of spacers W 50 mm	69209094
Adjustable tool holder				
 <p>Adjustable tool holder</p>	L1055001A		Single share plough	Z0020102
			Furrowing tool	Z0020133
			Potato digger	L0066400
Drives and Cutter plates				
 <p>Oil-immersed drive</p>	69229097A		0.95 m Complete central cutter plate Semi-fine teeth	69229084A*
			1.15 m Complete central cutter plate Semi-fine teeth	69229085A*
			1.27 m Complete central cutter plate Semi-fine teeth	69229086A*
			1.40 m Complete central cutter plate Semi-fine teeth	69229087A*
			0.95 m Complete central cutter plate Special teeth Side protection discs	69229068A
			1.15 m Complete central cutter plate Special teeth Side protection discs	69229069A
			1.27 m Complete central cutter plate Special teeth Side protection discs	69229070A
			1.40 m Complete central cutter plate Special teeth Side protection discs	69229071A
			1.22 m Complete central cutter plate "UNIVERSAL" ESM (requires kit L0058900)	69229036
			1.42 m Complete central cutter plate "UNIVERSAL" ESM (requires kit L0058900)	69229021
			1.02 m Complete central cutter plate "KOMUNAL" ESM (requires kit L0058900)	L0066900
			1.22 m Complete central cutter plate "KOMUNAL" ESM (requires kit L0058900)	69229037
			1.42 m Complete central cutter plate "KOMUNAL" ESM (requires kit L0058900)	69229038
			Ballast for oil-immersed drive	L0105700
	Directional guides for semi-fine tooth cutter plate	69229098		

* (recommended for use in conjunction with directional guides 69229098).



Accessories

Accessory		Optional accessory		
Front shovel				
	<p>Front shovel W 100x40 cm Quickfit coupling With horizontal and vertical adjustment (requires QuickFit 69212006)</p>	69209065		
Snow thrower				
	<p>Turbine W 60 cm Two stages Adjustable ejector chute Quickfit coupling (requires QuickFit 69212006)</p>	L0026200		
Front brush				
	<p>Brush W 100xØ 35 cm With horizontal and vertical adjustment Quickfit coupling (requires QuickFit 69212006)</p>	L0094200		
Rotor type flail mower				
	<p>Flail mower W 65 cm 24 'Y' shaped knives Integral safety brake Adjustable flange Adjustable support roller PTO right-hand rotation Quickfit coupling (requires QuickFit 69212006)</p>	L0091000		
Mower				
	<p>Mower W 65 cm Single blade Integral safety brake Adjustable and removable swivel wheels Adjustable lateral skids PTO right-hand rotation Quickfit coupling (requires QuickFit 69212006)</p>	69209008		
Trailer				
	<p>Towed trailer with handlebar steering Load box dimensions 1.25x0.95 m Load box depth 30 cm Wheels 145x70-8" Max load capacity 300 kg Pedal operated brake Parking handbrake Dump box Collapsible tailgate (not homologated for road use)</p>	L0018601		
QuickFit				
	<p>QuickFit coupling</p>	69212006		

Two wheel tractor for intensive use

KAM 13 S



Designed for professional users, with a 3-speed gearbox and differential, this machine, in its various different engine versions, is designed to take the most punishing conditions in its stride. Very versatile and safe, with its EHS system for easy clutch control this machine combines ruggedness and exceptional ease of handling. Individual user requirements can be met with the generous range of accessories available.



GIUCIARO DESIGN



Ergonomically positioned easy action levers for differential locking and reverse shuttle.



The EHS system ensures ease of use, reduced effort and the maximum simplification for users.



QuickFit coupling that allows the operator to change the tools without using tools.

KAM 13 S

Power supply	Engine	Model	Displacement	Power	Starting	Notes	Code
gasoline	Emak	K 1100 H	302 cm ³	8.4 HP	recoil start		68329238E5
gasoline	POWERED by HONDA	GX 270 OHV	270 cm ³	8.4 HP	recoil start		68329209E5
gasoline	POWERED by HONDA	GX 340 OHV	389 cm ³	10.7 HP	recoil start		68329210E5
gasoline	KOHLER	CH 395 OHV	277 cm ³	9.5 HP	recoil start		68329203E5
diesel	LOMBARDINI A KOHLER COMPANY	15LD350	349 cm ³	7.5 HP	recoil start		68329227E5
diesel	KIPOR	KM 186	406 cm ³	8.5 HP	recoil start		68329213EN **
diesel	Emak	K 9000 HD	441 cm ³	9.2 HP	recoil start/ electric	battery supplied as standard	68329236E5
diesel	LOMBARDINI A KOHLER COMPANY	15LD440	441 cm ³	10.9 HP	recoil start		68329211E5
diesel	LOMBARDINI A KOHLER COMPANY	15LD440	441 cm ³	10.9 HP	recoil start/ electric	battery supplied as standard	68329212E5

** Available while stocks last.

Focus on accessories



Rotor Ø 320, (80)-70-60-(50) cm
20 spikes
Quickfit included
Support wheel included
(expandable to 80 cm with kit **69210231**)
(can be reduced to 50 cm with kit **69210229**)
Code **69219059**



Turbine W 60 cm
Two stages
Adjustable ejector chute
Quickfit coupling
(requires QuickFit **69212006**)
Code **L0026200**



Flail mower W 65 cm
24 'Y' shaped knives
Integral safety brake
Adjustable flange
Adjustable support roller
PTO right-hand rotation
Quickfit coupling
(requires QuickFit **69212006**)
Code **L0091000**



WITH TWO WHEEL TRACTOR

Gearbox/ Speed (km/h):

6-speed (3 forward + 3 reverse) with 5.00-10" wheels

Speed (km/h)	1.26	1	1R	1.33
	2.64	2	2R	2.79
	4.37	3	3R	4.62

Dimensions (mm)

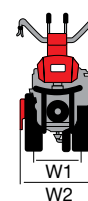
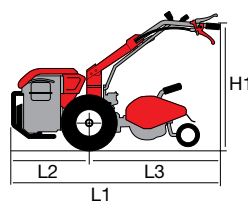

L1	1800
L2	690
L3	1110
H1	1470-630
W1	370
W2	800-400

WITH CUTTERBAR MOWER

Gearbox/ Speed (km/h):

6-speed (3 forward + 3 reverse) with 5.00-10" wheels

Speed (km/h)	1.33	1	1R	1.26
	2.79	2	2R	2.64
	4.62	3	3R	4.37

Dimensions (mm)

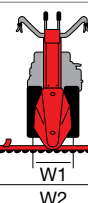
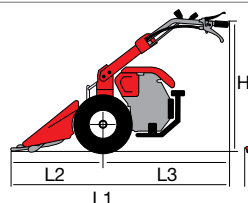













L1	1770
L2	900
L3	870
H1	1440-570
W1	370
W2	1420-950

Transmission	with oil-bath gearbox
Clutch	dry multidisc
Handlebars	with vertical and horizontal adjustment and 180° reversible, with vibration-damping device
Reverse gear	yes, with handlebar lever
Differential	yes
Brakes	yes
Power take-off	independent 973 rpm
Accessories installation	QuickFit (optional)
Towing hitch	yes
Cowling	yes
Weight	130 kg (with diesel engine, rotor and wheels)

Accessories



KAM 13 S

Accessory		Optional accessory		
Rotors				
 <p>Rotor Ø 280, 60-50-(40) cm 16 spikes Quickfit included (can be reduced to 40 cm with kit 69210259)</p>	69219088	 <p>Support wheel</p>	Z0020368	
		 <p>Rear-mounted furrowing tool</p>	L0009800	
 <p>Rotor Ø 320, (80)-70-60-(50) cm 20 spikes Quickfit included Support wheel included (expandable to 80 cm with kit 69210231) (can be reduced to 50 cm with kit 69210229)</p>	69219059	 <p>Rear-mounted furrowing tool</p>	L0009800	
		 <p>Rear-mounted furrowing tool</p>	L0009800	
 <p>Rotor Ø 320, (80)-70-60-(50) cm 24 spikes Quickfit included Support wheel included (can be reduced to 50 cm with kit 69210229)</p>	69219054	 <p>Rear-mounted furrowing tool</p>	L0009800	
		 <p>Rear-mounted furrowing tool</p>	L0009800	
 <p>Rotor Ø 320, (80)-70-60-(50) cm 20 spikes Fixed coupling Support wheel included (expandable to 80 cm with kit 69210231) (can be reduced to 50 cm with kit 69210229)</p>	69219065	 <p>Rear-mounted furrowing tool</p>	L0009800	
		 <p>Rear-mounted furrowing tool</p>	L0009800	



























Accessories

Accessory		Optional accessory		
Tyred wheels				
 <p>Pair of tyred wheels 4.00x8" Fixed disc</p>	69209025B	 <p>Screw-adjustable half-shafts</p>	69209105	
		 <p>5-hole adjustable half-shafts</p>	L0059500	
		 <p>Pair of spacers W 50 mm</p>	69209094	
		 <p>Pair of snow chains</p>	L1055015	
 <p>Pair of tyred wheels 4.00x10" Fixed disc</p>	69200024A	 <p>Screw-adjustable half-shafts</p>	69209105	
		 <p>5-hole adjustable half-shafts</p>	L0059500	
		 <p>Pair of spacers W 50 mm</p>	69209094	
		 <p>Pair of snow chains</p>	L0021600	
 <p>Pair of tyred wheels 4.00x10" Adjustable disc</p>	69209004B	 <p>Pair of 15 kg ballasts (not compatible with adjustable half-shafts)</p>	69209099	
		 <p>Pair of 15 kg ballasts (compatible with adjustable half-shafts)</p>	69209075	
		 <p>Screw-adjustable half-shafts</p>	69209105	
		 <p>5-hole adjustable half-shafts</p>	L0059500	
		 <p>Pair of spacers W 50 mm</p>	69209094	
		 <p>Pair of snow chains</p>	L0021600	
 <p>Pair of tyred wheels 5.00x10" Adjustable disc</p>	69209003B	 <p>Pair of 15 kg ballasts (not compatible with adjustable half-shafts)</p>	69209099	
		 <p>Pair of 15 kg ballasts (compatible with adjustable half-shafts)</p>	69209075	
		 <p>Screw-adjustable half-shafts</p>	69209105	
		 <p>5-hole adjustable half-shafts</p>	L0059500	
		 <p>Pair of spacers W 50 mm</p>	69209094	
		 <p>Pair of snow chains</p>	L0030200	
 <p>Pair of tyred wheels 16-6.50x8" Fixed disc</p>	69209012A	 <p>Screw-adjustable half-shafts</p>	69209105	
		 <p>5-hole adjustable half-shafts</p>	L0059500	

Accessories



KAM 13 S

Accessory		Optional accessory		
Steel wheels				
 Pair of steel wheels Ø 480x100 mm	69209067	 Pair of width adjustment rings W 100 mm	L0040100	
		 Screw-adjustable half-shafts	69209105	
		 5-hole adjustable half-shafts	L0059500	
		 Pair of spacers W 50 mm	69209094	
Adjustable tool holder				
 Adjustable tool holder	L1055001A	 Single share plough	Z0020102	
		 180° turnwrest plough	Z0020104	
		 Furrowing tool	Z0020133	
		 Fixed-tine cultivator	L0010200	
		 Potato digger	L0066400	
Drives and Cutter plates				
 Oil-immersed drive	69229097A	 0.95 m Complete central cutter plate Semi-fine teeth	69229084*	
		 1.15 m Complete central cutter plate Semi-fine teeth	69229085*	
		 1.27 m Complete central cutter plate Semi-fine teeth	69229086*	
		 1.40 m Complete central cutter plate Semi-fine teeth	69229087*	
		 0.95 m Complete central cutter plate Special teeth Side protection discs	69229068A	
		 1.15 m Complete central cutter plate Special teeth Side protection discs	69229069A	
		 1.27 m Complete central cutter plate Special teeth Side protection discs	69229070A	
		 1.40 m Complete central cutter plate Special teeth Side protection discs	69229071A	
		 1.22 m Complete central cutter plate "UNIVERSAL" ESM (requires kit L0058900)	69229036	
		 1.42 m Complete central cutter plate "UNIVERSAL" ESM (requires kit L0058900)	69229021	
		 1.02 m Complete central cutter plate "KOMUNAL" ESM (requires kit L0058900)	L0066900	
		 1.22 m Complete central cutter plate "KOMUNAL" ESM (requires kit L0058900)	69229037	
		 1.42 m Complete central cutter plate "KOMUNAL" ESM (requires kit L0058900)	69229038	
		 Ballast for oil-immersed drive	L0105700	
 Directional guides for semi-fine tooth cutter plate	69229098			

* (recommended for use in conjunction with directional guides 69229098).



Accessories

Accessory		Optional accessory		
Front shovel				
	<p>Front shovel W 100x40 cm Quickfit coupling With horizontal and vertical adjustment (requires QuickFit 69212006)</p>	69209065		
Snow thrower				
	<p>Turbine W 60 cm Two stages Adjustable ejector chute Quickfit coupling (requires QuickFit 69212006)</p>	L0026200		
Front brush				
	<p>Brush W 100xØ 35 cm With horizontal and vertical adjustment Quickfit coupling (requires QuickFit 69212006)</p>	L0094200		
Rotor type flail mower				
	<p>Flail mower W 65 cm 24 'Y' shaped knives Integral safety brake Adjustable flange Adjustable support roller PTO right-hand rotation Quickfit coupling (requires QuickFit 69212006)</p>	L0091000		
Mower				
	<p>Mower W 75 cm Single blade Integral safety brake Adjustable and removable swivel wheels Adjustable lateral skids PTO right-hand rotation Quickfit coupling (requires QuickFit 69212006)</p>	69209007		
Trailer				
	<p>Towed trailer with handlebar steering Load box dimensions 1.25x0.95 m Load box depth 30 cm Wheels 145x70-8" Max load capacity 300 kg Pedal operated brake Parking handbrake Dump box Collapsible tailgate (not homologated for road use)</p>	L0018601		
QuickFit				
	<p>QuickFit coupling</p>	69212006		

Professional two wheel tractor

MAK 17 S



Professional machine with power rating and features that recommend it for root crop harvesting and tillage duties on all terrain types. Combines exceptional ease of handling and versatility with the ability to work on all types of terrain safely, thanks to the self-locking differential and 5-speed gearbox.



The EHS system ensures ease of use, reduced effort and the maximum simplification for users.



Multidisc version supplied as standard with Giugiaro design cowling.



Two power take-offs, one independent two-speed PTO and one synchronised PTO.

MAK 17 S

Power supply	Engine	Model	Displacement	Power	Starting	Notes	Code
gasoline	POWERED BY HONDA	GX 340 OHV	389 cm ³	10.7 HP	recoil start	multidisc clutch	68339118E5
gasoline	KOHLER	CH 395 OHV	277 cm ³	9.5 HP	recoil start/ electric	multidisc clutch/ battery supplied as standard	68339114E5
gasoline	KOHLER	CH 440 OHV	429 cm ³	14.0 HP	recoil start/ electric	mono-disc clutch/ battery supplied as standard	68339115E5
diesel	LOMBARDINI A KOHLER COMPANY	15LD440	441 cm ³	10.9 HP	recoil start	multidisc clutch	68339109E5
diesel	LOMBARDINI A KOHLER COMPANY	15LD440	441 cm ³	10.9 HP	recoil start/ electric	multidisc clutch/ battery supplied as standard	68339108E5
diesel	KOHLER	KD 15 440	441 cm ³	10.9 HP	recoil start/ electric	mono-disc clutch/ lights/ battery supplied as standard	68339110E5
diesel	LOMBARDINI A KOHLER COMPANY	3LD510	505 cm ³	12.2 HP	recoil start	mono-disc clutch	68339111EN
diesel	LOMBARDINI A KOHLER COMPANY	3LD510	505 cm ³	12.2 HP	electric	mono-disc clutch/ battery supplied as standard	68339112EN
diesel	LOMBARDINI A KOHLER COMPANY	3LD510	505 cm ³	12.2 HP	electric	mono-disc clutch/ lights/ battery supplied as standard	68339113EN

Focus on accessories



Rotor Ø 350, 80-65 cm
16 spikes
Fixed coupling
Support wheel included
Code **69219072**



Single share plough
Code **Z0020102**



Flail mower **W 80 cm**
32 'Y'-shaped knives
Integral safety brake
Adjustable flange
Adjustable support roller
PTO left-hand rotation
Fixed coupling



WITH TWO WHEEL TRACTOR

Gearbox/ Speed (km/h):

5-speed (4 forward + 1 reverse) with 6.50/80-12" wheels

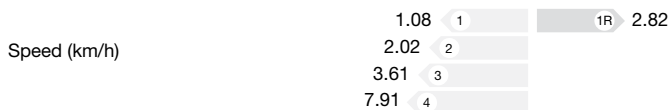

Dimensions (mm)

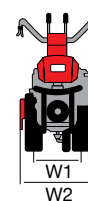
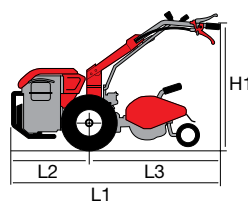

L1	2180
L2	730
L3	1450
H1	600-1300
W1	420-510
W2	600-900

WITH CUTTERBAR MOWER

Gearbox/ Speed (km/h):

5-speed (4 forward + 1 reverse) with 6.50/80-12" wheels

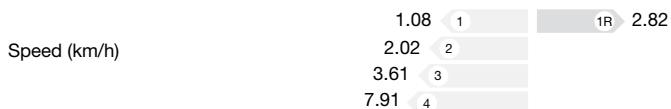

Dimensions (mm)

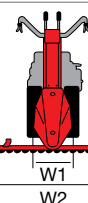
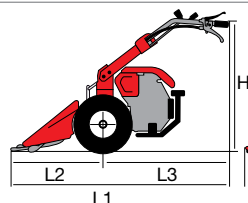





L1	2185
L2	1125
L3	1060
H1	700-1300
W1	430-490
W2	1150-1600

Transmission	with oil-bath gearbox
Clutch	dry multidisc or mono-disc
Handlebars	with vertical and horizontal adjustment and 180° reversible, with vibration-damping device
Reverse gear	yes, with lever alongside gearbox
Differential	yes
Brakes	yes
Power take-off	2 power take-offs: one independent 2-speed PTO (1° 540 rpm - 2° 900 rpm) and one synchronised PTO
Accessories installation	with flange on PTO
Towing hitch	yes
Cowling	yes, with integral tool compartment/battery box
Weight	250 kg (with diesel engine, rotor and wheels)

















Accessories



MAK 17 S

Accessory		Optional accessory		
Rotors for engines < 11 HP				
 <p>Rotor Ø 320, (80)-70-60-(50) cm 20 spikes Fixed coupling Support wheel included (expandable to 80 cm with kit 69210231) (can be reduced to 50 cm with kit 69210229)</p>	69219069		Rear-mounted furrowing tool	L0009800
 <p>Rotor Ø 320, 80-70-60-(50) cm 24 spikes Fixed coupling Support wheel included (can be reduced to 50 cm with kit 69210229)</p>	69219067		Rear-mounted furrowing tool	L0009800
Rotors for engines > 11 HP				
 <p>Rotor Ø 350, 80-65 cm 20 spikes Fixed coupling Support wheel included</p>	69219071		Rear-mounted furrowing tool	Z0020134
 <p>Rotor Ø 350, 80-65 cm 16 spikes Fixed coupling Support wheel included</p>	69219072		Rear-mounted furrowing tool	Z0020134

Accessories

Accessory		Optional accessory		
Tyred wheels				
 <p>Pair of tyred wheels 5.00x10" Adjustable disc</p>	69209003B	 <p>Pair of 15 kg ballasts (not compatible with adjustable half-shafts)</p>	69209099	
		 <p>Pair of 15 kg ballasts (compatible with adjustable half-shafts)</p>	69209075	
		 <p>Screw-adjustable half-shafts</p>	69209105	
		 <p>5-hole adjustable half-shafts</p>	L0059500	
		 <p>Pair of spacers W 95 mm</p>	69209095	
		 <p>Pair of snow chains</p>	L0030200	
 <p>Pair of tyred wheels 5.00x12" Adjustable disc</p>	69209002B	 <p>Pair of ballasts 25 kg (compatible with adjustable half-shafts)</p>	69209077	
		 <p>Screw-adjustable half-shafts</p>	69209105	
		 <p>5-hole adjustable half-shafts</p>	L0059500	
		 <p>Pair of spacers W 95 mm</p>	69209095	
 <p>Pair of tyred wheels 6.5/80x12" Adjustable disc</p>	69200038B	 <p>Pair of ballasts 25 kg (compatible with adjustable half-shafts)</p>	69209077	
		 <p>Screw-adjustable half-shafts</p>	69209105	
		 <p>5-hole adjustable half-shafts</p>	L0059500	
		 <p>Pair of spacers W 95 mm</p>	69209095	

Accessories





MAK 17 S

Accessory		Optional accessory		
Steel wheels				
	Pair of steel wheels Ø 570x125 mm 69209068		Pair of width adjustment rings W 100 mm 69209069	
			Screw-adjustable half-shafts 69209105	
			5-hole adjustable half-shafts L0059500	
			Pair of spacers W 95 mm 69209095	
Adjustable tool holder				
	Adjustable tool holder Z0020172		Single share plough Z0020102	
			180° turnwrest plough Z0020104	
			Furrowing tool Z0020133	
			Fixed-tine cultivator (not compatible with 5.00x10" wheels) L0010200	
			Potato digger (not compatible with 5.00x10" wheels) L0066400	
Drives and Cutter plates				
	Oil-immersed drive L0101500A		1.15 m Complete central cutter plate Semi-fine teeth 69229085A*	
			1.27 m Complete central cutter plate Semi-fine teeth 69229086A*	
			1.40 m Complete central cutter plate Semi-fine teeth 69229087A*	
			0.95 m Complete central cutter plate Special teeth Side protection discs 69229068A	
			1.15 m Complete central cutter plate Special teeth Side protection discs 69229069A	
			1.27 m Complete central cutter plate Special teeth Side protection discs 69229070A	
			1.40 m Complete central cutter plate Special teeth Side protection discs 69229071A	
			1.22 m Complete central cutter plate "UNIVERSAL" ESM (requires kit L0058900) 69229036	
			Ballast for oil-immersed drive L0105700	
			Directional guides for semi-fine tooth cutter plate 69229098	
Lighting				
	Supplementary worklight kit (versions with electric starting only) 69209113			

* (recommended for use in conjunction with directional guides **69229098**).

Accessories

Accessory		Optional accessory			
Roller flail mower					
	Flail mower W 80 cm 32 'Y'-shaped knives Integral safety brake Adjustable flange Adjustable support roller PTO left-hand rotation Fixed coupling	69209120			
Mower					
	Mower W 75 cm Single blade Integral safety brake Adjustable and removable swivel wheels Adjustable lateral skids PTO left-hand rotation Fixed coupling	69209121			

Professional two wheel tractor

MAK 18 S



Its characteristics of high power and reliability make this model perfect for farmers and ground care professionals. Combines exceptional ease of handling and versatility with the ability to work on all types of terrain safely, thanks to the self-locking differential and 5-speed gearbox. The powerful engines available for this model are exploited in full thanks to the reinforced half-shafts, while the large size final reduction gears on the axle ensure efficient transmission of the full engine power while increasing the machine's ground clearance.



Reinforced half-shafts with final reduction drives incorporated in the transmission assembly for more grip on difficult terrain.



Two power take-offs, one independent two-speed PTO and one synchronised PTO.



Accessories coupling by means of flange on the PTO.

MAK 18 S

Power supply	Engine	Model	Displacement	Power	Starting	Notes	Code
diesel	LOMBARDINI	3LD510	505 cm ³	12.2 HP	electric	mono-disc clutch/ lights/ battery supplied as standard	68339150AEN
diesel	LOMBARDINI	25LD330	654 cm ³	16.3 HP	electric	mono-disc clutch/ lights/ battery supplied as standard	68339151AEN
diesel	LOMBARDINI	25LD425	851 cm ³	19.0 HP	electric	mono-disc clutch/ lights/ battery supplied as standard	68339152E5

Focus on accessories



Rotor Ø 350, 80-65 cm
16 spikes
Fixed coupling
Support wheel
Code **69219072**



Adjustable tool holder
Code **Z0020172**



180° turnwrest plough
Code **Z0020107**



WITH TWO WHEEL TRACTOR

Gearbox/ Speed (km/h):

5-speed (4 forward + 1 reverse) with 6.50/80-12" wheels

Speed (km/h)

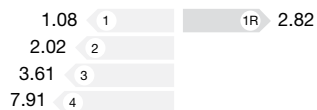

Dimensions (mm)

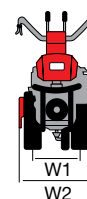
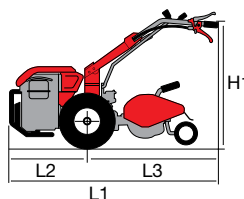

L1	2180
L2	730
L3	1450
H1	600-1300
W1	420-510
W2	600-900

WITH CUTTERBAR MOWER

Gearbox/ Speed (km/h):

5-speed (4 forward + 1 reverse) with 6.50/80-12" wheels

Speed (km/h)

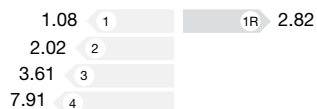

Dimensions (mm)

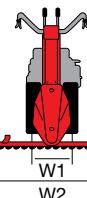
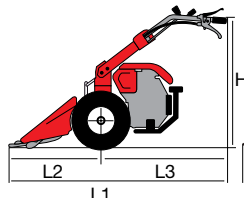

L1	2185
L2	1125
L3	1060
H1	700-1300
W1	450-510
W2	1150-1600

Transmission	with oil-bath gearbox
Clutch	dry mono-disc
Handlebars	with vertical and horizontal adjustment and 180° reversible, with vibration-damping device
Reverse gear	yes, with lever alongside gearbox
Differential	yes
Brakes	yes
Power take-off	2 power take-offs one independent 2-speed PTO (1° 540 rpm - 2° 900 rpm) and one synchronised PTO
Accessories installation	flanged to PTO
Towing hitch	yes
Cowling	yes, with integral tool compartment/battery box
Weight	270 kg (with diesel engine, rotor and wheels)

















Accessories



MAK 18 S

Accessory		Optional accessory		
Rotors				
	Rotor Ø 350, 80-65 cm 20 spikes Fixed coupling Support wheel	69219071		Rear-mounted furrowing tool Z0020134
	Rotor Ø 350, 80-65 cm 16 spikes Fixed coupling Support wheel	69219072		Rear-mounted furrowing tool Z0020134
	Rotor Ø 350, 80-65 cm 20 spikes Fixed coupling with tiller shaft adapter Support wheel (compatible with 6.50/80-15" wheels only)	69219074		Rear-mounted furrowing tool Z0020134
	Rotor Ø 350, 80-65 cm 16 spikes Fixed coupling with tiller shaft adapter Support wheel (compatible with 6.50/80-15" wheels only)	69219075		Rear-mounted furrowing tool Z0020134
	Rotor Ø 350, 90-65 cm 16 spikes Fixed coupling with tiller shaft adapter Support wheel (compatible with 6.50/80-15" wheels only)	69219079		Rear-mounted furrowing tool Z0020134
Tyred wheels				
	Pair of tyred wheels 6.5/80x12" Adjustable disc	69200038B		Pair of ballasts 25 kg (compatible with adjustable half-shafts) 69209077
				Screw-adjustable half-shafts 69209105
				5-hole adjustable half-shafts L0059500
				Pair of spacers W 95 mm 69209095
	Pair of tyred wheels 6.5/80x15" Adjustable disc	69209013		Pair of ballasts 25 kg 69209077

Accessories

Accessory		Optional accessory		
Adjustable tool holder				
 <p>Adjustable tool holder</p>	Z0020172		Single share plough	Z0020102
			180° turnwrest plough	Z0020107
			Furrowing tool	Z0020133
			Fixed-tine cultivator	L0010200
			Potato digger	L0066400
Drives and Cutter plates				
 <p>Oil-immersed drive</p>	L0101500A		1.15 m Complete central cutter plate Semi-fine teeth	69229085A
			1.27 m Complete central cutter plate Semi-fine teeth	69229086A
			1.40 m Complete central cutter plate Semi-fine teeth	69229087A
			0.95 m Complete central cutter plate Special teeth Side protection discs	69229068A
			1.27 m Complete central cutter plate Special teeth Side protection discs	69229070A
			1.40 m Complete central cutter plate Special teeth Side protection discs	69229071A
			1.22 m Complete central cutter plate "UNIVERSAL" ESM (requires kit L0058900)	69229036
			Ballast for oil-immersed drive	L0105700
			Directional guides for semi-fine tooth cutter plate	69229098
Roller flail mower				
	<p>Flail mower W 80 cm 32 'Y'-shaped knives Integral safety brake Adjustable flange Adjustable support roller PTO left-hand rotation Fixed coupling</p>	69209120		
Mower				
	<p>Mower W 75 cm Single blade Integral safety brake Adjustable and removable swivel wheels Adjustable lateral skids PTO left-hand rotation Fixed coupling</p>	69209121		

* (recommended for use in conjunction with directional guides 69229098).

Professional machines for shredding and chopping grass, shoots and green waste generally, powerful and reliable for finishing jobs.



Flail mowers

PROFESSIONAL



NTS 65



NTS 80



TECHNICAL DATA



gearbox



power



knives



working width

Professional flail mower

NTS 65



High-performance, reliable model designed for the needs of farmers and professional operators. Grass, shoots, twigs and low vegetation, scrub and stubble: this machine stops at nothing, assuring excellent cleaning of ground, orchards and vineyards thanks to its highly efficient and powerful cutting unit and wide working width.



Independent steering clutches on the driving wheels, with wheel lock, which make the machine extremely easy to handle.



The handlebars have 4 vertical adjustment positions and 5 horizontal adjustment positions.



The front directional wheels can be locked to facilitate work on sloping surfaces.

NTS 65

Power supply	Engine	Model	Displacement	Power	Starting	Code
gasoline	Emak	K 1100 H	302 cm ³	8.4 HP	recoil start	68249023E5
gasoline	POWERED by HONDA	GX 340 OHV	389 cm ³	10.7 HP	recoil start	68249009E5

Focus on accessories



Pair of steel wheels + Width adjustment ring
Steel wheels Ø 410 mm
Code **68242001**



Gearbox/ Speed (km/h):

4-speed (3 forward + 1 reverse) with 16/6.50-8" wheels

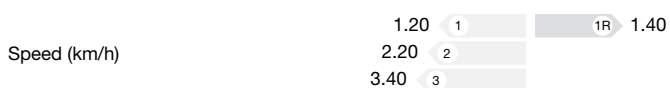

Dimensions (mm)

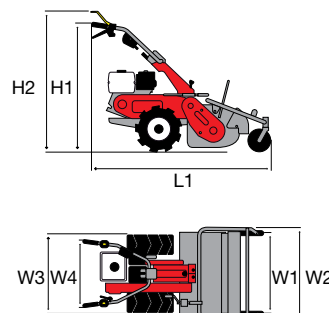

L1	1657
H1	1092
H2	1216
W1	700
W2	814
W3	670
W4	550

Transmission	with oil-bath gearbox
Clutch	belt with tensioner
Steering	with independent steering clutches and wheel lock
Handlebars	with vertical and horizontal adjustment
Cutting unit	rotor with 38 'Y' shaped knives
Working width	65 cm
Cutting height	20 to 80 mm, adjustable with handle
Service brake	with automatic engagement
Front wheels	swivel with lock
Rear wheels	16/6.50-8"
Weight	160 kg

Professional flail mower

NTS 80



High-performance, extremely reliable machine offering the same professional performance as the smaller model, with a more powerful engine and greater cutting width for excellent results under all conditions.



Rotor with powerful and sturdy 'Y' shaped knives to cut and shred grass and clippings efficiently with no risk of impact or damage.



The gear selection lever on the handlebar is simple to operate.



The service and parking brake engages automatically when the clutch is released, to prevent accidental hazardous movements.

NTS 80

Power supply	Engine	Model	Displacement	Power	Starting	Code
gasoline	POWERED by HONDA	GX 340 OHV	389 cm ³	10.7 HP	recoil start	68249022E5

Focus on accessories



Pair of steel wheels + Width adjustment ring
Steel wheels Ø 410 mm
Code **68242001**



Gearbox/ Speed (km/h):

4-speed (3 forward + 1 reverse) with 16/6.50-8" wheels

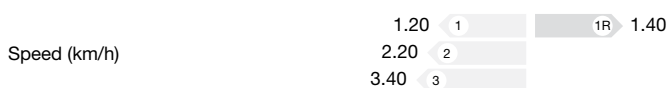

Dimensions (mm)

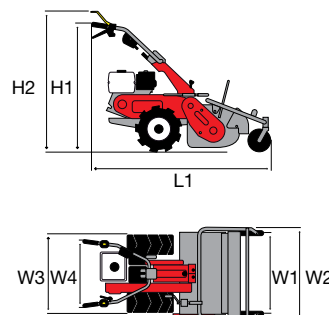

L1	1657
H1	1092
H2	1216
W1	850
W2	964
W3	670
W4	550

Transmission	with oil-bath gearbox
Clutch	belt with tensioner
Steering	with independent steering clutches and wheel lock
Handlebars	with vertical and horizontal adjustment
Cutting unit	rotor with 46 'Y' shaped knives
Working width	80 cm
Cutting height	20 to 80 mm, adjustable with handle
Service brake	with automatic engagement
Front wheels	swivel with lock
Rear wheels	16/6.50-8"
Weight	175 kg

Easy to steer and handle for
a precise cut and
consistently high performance
in all working conditions.



Cutterbar mowers

HOME



FC 110



FC 120



INTENSIVE



FC 130 S



FC 20



PROFESSIONAL



FC 30



TECHNICAL DATA



gearbox



power



cutter bar



differential block



reverse gear



brakes

OPTIONAL



cutter bar



brush



turbine



shovel



flail mower



mower

Cutterbar mower for home use

FC 110



Configured for a centrally mounted cutterbar, this lightweight and manoeuvrable machine is designed to meet the requirements of non-professional users. The machine is primarily used to cut grass and fodder crops and for general clearing duties outside the garden.



Handlebars with vertical adjustment to allow the operator to assume the correct posture while working.



Handlebar mounted on vibration dampers.



Integral QuickFit coupling that allows the operator to change the tools without using tools.

FC 110

Power supply	Engine	Model	Displacement	Power	Starting	Code
gasoline	Emak	K 700 H OHV	182 cm ³	5.4 HP	recoil start	68939002E5

Focus on accessories



Pair of tyred wheels 3.50x6"
Fixed disc
Code **69209107**



Cam drive
Code **69222009**



Complete central cutter plate 0.92 m
Special teeth
Code **69222011**



Gearbox/ Speed (km/h):

1-speed (1 forward) with 3.50-6" wheels

Speed (km/h)

2.30

1

Dimensions (mm)

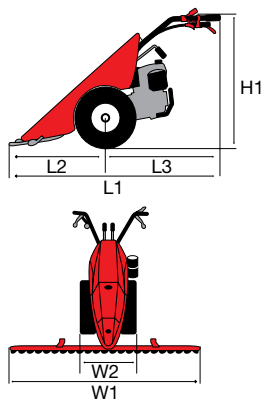

L1	1540
L2	740
L3	800
H1	990
W1	920
W2	400

Transmission	with oil-bath gearbox
Clutch	direct engagement
Handlebars	with vertical adjustment and anti-vibration device
Reverse gear	no
Differential	no
Brakes	no
Power take-off	independent 1017 rpm
Accessories installation	QuickFit supplied as standard
Weight	70 kg (with wheels, bar drive and cutter)

Cutterbar mower for home use

FC 120



The machine is primarily used to cut grass and fodder crops and for general field clearing duties. Features such as the vertically and horizontally adjustable handlebars, the QuickFit system, and transmission available also with oil-immersed drive reflect the high level of attention paid to the operator.



Handlebar-mounted PTO control.



Handlebars with vertical and horizontal adjustment and vibration-damping device to assure more comfortable handling.



Integral QuickFit coupling that allows the operator to change the tools without using tools.

FC 120

Power supply	Engine	Model	Displacement	Power	Starting	Code
gasoline	POWERED BY HONDA	GX 160 OHV	163 cm ³	4.8 HP	recoil start	68919133X5
gasoline	Emak	K 800 H OHV	182 cm ³	5.7 HP	recoil start	68919135X5
gasoline	KOHLER	CH 270 OHV	208 cm ³	7.0 HP	recoil start	68919136X5

Focus on accessories



Cam drive
Code **69229092**



Complete central cutter plate
0.92 m
Special teeth
Code **69222011**



Brush W 80-Ø 35 cm
With horizontal and vertical adjustment
Code **L0070000**



Gearbox/ Speed (km/h):

2-speed (1 forward + 1 reverse) with 4.00-8" wheels

Speed (km/h)

3.07 **1** **1R** 1.18

Dimensions (mm)

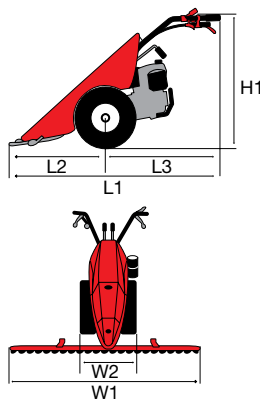

L1	1465
L2	600
L3	865
H1	1150
W1	920-1220
W2	465

Transmission	with oil-bath gearbox
Clutch	dry multidisc
Handlebars	with vertical and horizontal adjustment and anti-vibration device
Reverse gear	no
Differential	no
Brakes	no
Power take-off	independent 1004 rpm
Accessories installation	QuickFit supplied as standard
Weight	80 kg (with wheels, bar drive and cutter)

Accessories



FC 120

Accessory		Optional accessory		
Tyred wheels				
	Pair of tyred wheels 4.00x8" Fixed disc	69209025B		Pair of snow chains L1055015
Steel wheels				
	Pair of steel wheels Ø 480x100 mm (installable directly on the hubs or in combination with wheels 69209025B)	69209067		Pair of width adjustment rings W 100 mm L0040100
Drives and Cutter plates				
	Cam drive	69229092		0.92 m Complete central cutter plate Special teeth 69222011
	Oil-immersed drive	69229032		0.95 m Complete central cutter plate Semi-fine teeth 69229084*
				1.15 m Complete central cutter plate Semi-fine teeth 69229085A*
				0.95 m Complete central cutter plate Special teeth Side protection discs 69229068A
				1.15 m Complete central cutter plate Special teeth Side protection discs 69229069A
				1.22 m Complete central cutter plate "UNIVERSAL" ESM (requires kit L0058900) 69229036
				1.02 m Complete central cutter plate "KOMUNAL" ESM (requires kit L0058900) L0066900
				1.22 m Complete central cutter plate "KOMUNAL" ESM (requires kit L0058900) 69229037
				Directional guides for semi-fine tooth cutter plate 69229098
				Ballast for oil-immersed drive L0105700
Front brush				
	Brush W 80-Ø 35 cm With horizontal and vertical adjustment	L0070000		

* (recommended for use in conjunction with directional guides 69229098).



Cutterbar mower for intensive use

FC 130 S



Designed for use in small and medium-sized plots, in a highly effective and reliable manner this machine combines professional level features and performance with exceptional manoeuvrability, making it ideal for demanding home users and smallholders. The wide range of accessories available, including cutter bars, brushes and snow throwers, meet the requirements of those who are seeking a multifunctional machine that's easy to use and completely safe.



Handlebars with vertical and horizontal adjustment and vibration-damping device for more comfortable use of the machine.



The EHS system ensures ease of use, reduced effort and the maximum simplification for users.



Practical forward/reverse shuttle enables the operator to select reverse quickly from any speed. This feature makes the machine exceptionally manoeuvrable in various different work activities.

FC 130 S

Power supply	Engine	Model	Displacement	Power	Starting	Code
gasoline	POWERED BY HONDA	GX 200 OHV	196 cm ³	5.8 HP	recoil start	68949004E5
gasoline	Emak	K 800 H OHV	182 cm ³	5.7 HP	recoil start	68949003E5

Focus on accessories



Brush W 100xØ 35 cm
With horizontal and vertical adjustment
Quickfit coupling
Code **L0094200**



Oil-immersed drive
Code **69229097A**



Front shovel W 100x40 cm
Quickfit coupling
With horizontal and vertical adjustment
Code **69209065**



Gearbox/ Speed (km/h):

4-speed (2 forward + 2 reverse) with 4.00-8" wheels

Speed (km/h)

1.11	1	1R	1.05
2.32	2	2R	2.20

Dimensions (mm)

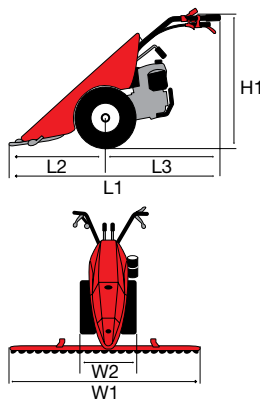



















L1	1670
L2	900
L3	770
H1	1250-300
W1	1270-950
W2	450

Transmission	with oil-bath gearbox
Clutch	dry bevel type
Handlebars	with vertical and horizontal adjustment and vibration-damping device
Reverse gear	yes, with handlebar lever
Differential	no
Brakes	no
Power take-off	independent 973 rpm
Accessories installation	QuickFit supplied as standard
Weight	105 kg (with wheels, bar drive and cutter)

Accessories



FC 130 S

Accessory		Optional accessory	
Tyred wheels			
	Pair of tyred wheels 4.00x8" Fixed disc Quickfit coupling	69209110	 Pair of snow chains L1055015
	Pair of tyred wheels 4.00x10" Fixed disc (requires spacers 69209112)	69200024A	 Pair of snow chains L0021600
Steel wheels			
	Pair of steel wheels Ø 480x100 mm (requires spacers 69209112)	69209067	 Pair of width adjustment rings W 100 mm L0040100
Drives and Cutter plates			
 Oil-immersed drive	69229097A	 0.95 m Complete central cutter plate Semi-fine teeth	69229084A*
		 1.15 m Complete central cutter plate Semi-fine teeth	69229085A*
		 1.27 m Complete central cutter plate Semi-fine teeth	69229086A*
		 0.95 m Complete central cutter plate Special teeth Side protection discs	69229068A
		 1.15 m Complete central cutter plate Special teeth Side protection discs	69229069A
		 1.27 m Complete central cutter plate Special teeth Side protection discs	69229070A
		 1.22 m Complete central cutter plate "UNIVERSAL" ESM (requires kit L0058900)	69229036
		 1.02 m Complete central cutter plate "KOMUNAL" ESM (requires kit L0058900)	L0066900
		 1.22 m Complete central cutter plate "KOMUNAL" ESM (requires kit L0058900)	69229037
		 Ballast for oil-immersed drive	L0105700
		 Directional guides for semi-fine tooth cutter plate	69229098

* (recommended for use in conjunction with directional guides **69229098**).



Accessories

Accessory		Optional accessory		
Front shovel				
 <p>Front shovel W 100x40 cm Quickfit coupling With horizontal and vertical adjustment</p>	69209065			
Snow thrower				
 <p>Turbine W 60 cm Two stages Adjustable ejector chute Quickfit coupling</p>	L0026200			
Front brush				
 <p>Brush W 100xØ 35 cm With horizontal and vertical adjustment Quickfit coupling</p>	L0094200			
Roller flail mower				
 <p>Flail mower W 50 cm 16 "Y" shaped knives Integral safety brake Adjustable flange Adjustable support roller PTO right-hand rotation Quickfit coupling</p>	69209119			
Mower				
 <p>Mower W 65 cm Single blade Integral safety brake Adjustable and removable swivel wheels Adjustable lateral skids PTO right-hand rotation Quickfit coupling</p>	69209008			

Cutterbar mower for intensive use

FC 20



Configured for a centrally mounted cutterbar, this lightweight and easy-to-handle machine was designed to satisfy the needs of semi-professional users. It is used mainly for cutting grass and forage crops and for field cleaning. Details including the height-adjustable handlebars, rapid forward/reverse shuttle, Quickfit system and optional oil-bath transmission all demonstrate the close attention paid to operator comfort and safety.



Rapid forward/reverse shuttle, controlled from the handlebar: used to invert the operating direction without touching the gears.



Integral QuickFit coupling that allows the operator to change the tools without using tools.



Handlebars with vertical adjustment and vibration-damping device to assure more comfortable handling.

FC 20

Power supply	Engine	Model	Displacement	Power	Starting	Code
gasoline	Emak	K 900 H OHV	252 cm ³	7.0 HP	recoil start	68919006X5
gasoline	POWERED BY HONDA	GX 270 OHV	270 cm ³	8.4 HP	recoil start	68919064X5
gasoline	KOHLER	CH 395 OHV	277 cm ³	9.5 HP	recoil start	68919070X5

Focus on accessories



Oil-immersed drive
Code **69229025**



Front shovel W 100x40 cm
Quickfit coupling
With horizontal and vertical adjustment
Code **69209065**



Brush W 100xØ 35 cm
With horizontal and vertical adjustment
Quickfit coupling
Code **L0094200**



Gearbox/ Speed (km/h):

7-speed (4 forward + 3 reverse) with 4.00-8" wheels

Speed (km/h)

1.05	1	1R	1.11
2.20	2	2R	2.32
3.63	3	3R	3.83
11.38	4		

Dimensions (mm)

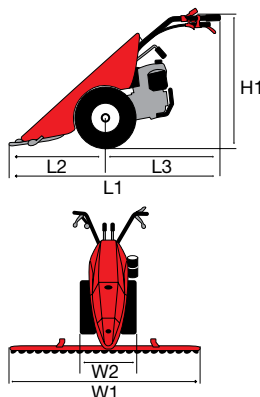























L1	1660 (1665)
L2	900 (950)
L3	760
H1	1250-400
W1	950-1450
W2	437

Transmission	with oil-bath gearbox
Clutch	dry multidisc
Handlebars	with vertical adjustment and anti-vibration device
Reverse gear	yes, with handlebar lever
Differential	no
Brakes	no
Power take-off	independent 973 rpm
Accessories installation	QuickFit supplied as standard
Weight	115 kg (with wheels, bar drive and cutter)

















Accessories



FC 20

Accessory		Optional accessory			
Tyred wheels					
	Pair of tyred wheels 4.00x8" Fixed disc	69209025B		Pair of spacers W 50 mm	69209094
				Pair of spacers W 130 mm For fitting twin wheels	69209097
				Pair of snow chains	L0021600
	Pair of tyred wheels 4.00x10" Fixed disc	69200024		Pair of spacers W 50 mm	69209094
				Pair of spacers W 130 mm For fitting twin wheels	69209097
				Pair of snow chains	L0021600
	Pair of tyred wheels 4.00x10" Adjustable disc	69209004B		Pair of spacers W 50 mm	69209094
				Pair of spacers W 130 mm For fitting twin wheels	69209097
				Pair of tyre crampons 10"	L0033800
				Pair of snow chains	L0021600
	Pair of tyred wheels 5.00x10" Adjustable disc	69209003B		Pair of spacers W 50 mm (required for DIESEL engines)	69209094
				Pair of spacers W 150 mm For fitting twin wheels	69209098
				Pair of snow chains	L0030200
	Pair of tyred wheels 16-6.50/8" Fixed disc	69209012A		Pair of spacers W 50 mm (required for assembly)	69209094
	Pair of tyred wheels 18-9.50/8" Fixed disc	69209104		Pair of spacers W 100 mm (required for assembly)	69209103
Steel wheels					
	Pair of steel wheels Ø 480x100 mm	69209067		Pair of width adjustment rings W 100 mm	L0040100

Accessories

Accessory	Optional accessory			
 <p>Oil-immersed drive</p>	69229025		<p>0.95 m Complete central cutter plate Semi-fine teeth</p>	69229084A*
			<p>1.15 m Complete central cutter plate Semi-fine teeth</p>	69229085A*
			<p>1.27 m Complete central cutter plate Semi-fine teeth</p>	69229086A*
			<p>1.40 m Complete central cutter plate Semi-fine teeth</p>	69229087A*
			<p>0.95 m Complete central cutter plate Special teeth Side protection discs</p>	69229068A
			<p>1.15 m Complete central cutter plate Special teeth Side protection discs</p>	69229069A
			<p>1.27 m Complete central cutter plate Special teeth Side protection discs</p>	69229070A
			<p>1.40 m Complete central cutter plate Special teeth Side protection discs</p>	69229071A
			<p>1.22 m Complete central cutter plate "UNIVERSAL" ESM (requires kit L0058900)</p>	69229036
			<p>1.42 m Complete central cutter plate "UNIVERSAL" ESM (requires kit L0058900)</p>	69229021
			<p>1.02 m Complete central cutter plate "KOMUNAL" ESM (requires kit L0058900)</p>	L0066900
			<p>1.22 m Complete central cutter plate "KOMUNAL" ESM (requires kit L0058900)</p>	69229037
			<p>1.42 m Complete central cutter plate "KOMUNAL" ESM (requires kit L0058900)</p>	69229038
			<p>Directional guides for semi-fine tooth cutter plate</p>	69229098
			<p>Ballast for mechanical drive</p>	L0105500
	<p>Ballast for oil-immersed drive</p>	L0105700		

* (recommended for use in conjunction with directional guides 69229098).

Accessories



FC 20

Accessory		Optional accessory		
Front shovel				
 <p>Front shovel W 100x40 cm Quickfit coupling With horizontal and vertical adjustment</p>	69209065			
Snow thrower				
 <p>Turbine W 60 cm Two stages Adjustable ejector chute Quickfit coupling</p>	L0026200			
Front brush				
 <p>Brush W 100xØ 35 cm With horizontal and vertical adjustment Quickfit coupling</p>	L0094200			
Rotor type flail mower				
 <p>Flail mower W 65 cm 24 "Y" shaped knives Integral safety brake Adjustable flange Adjustable support roller PTO right-hand rotation Quickfit coupling</p>	L0091000			
Mower				
 <p>Mower W 75 cm Single blade Integral safety brake Adjustable and removable swivel wheels Adjustable lateral skids PTO right-hand rotation Quickfit coupling</p>	69209007			



Professional cutterbar mower

FC 30



The model FC 30 completes the semi-professional range: this is the ideal machine for mowing grass and forage crops or cleaning in open fields. With an excellent combination of power and easy handling, this cutterbar mower is fitted with independently controlled brakes as standard.



Independent brakes on each wheel supplied as standard.



Practical forward/reverse shuttle enables the operator to change quickly into reverse gear at any speed.



Differential supplied as standard, to facilitate manoeuvres, also on gradients.

FC 30

Power supply	Engine	Model	Displacement	Power	Starting	Code
gasoline	Emak	K 1100 H	302 cm ³	8.4 HP	recoil start	68919003X5
gasoline	POWERED BY HONDA	GX 270 OHV	270 cm ³	8.4 HP	recoil start	68919035X5
diesel	Emak	K 7000 HD	349 cm ³	6.5 HP	recoil start	68919008X5

Focus on accessories



Oil-immersed drive
Code **69229025**



Complete central cutter plate
1.15 m
Special teeth
Side protection discs
Code **69229069A**



Turbine W 60 cm
Two stages
Adjustable ejector chute
Quickfit coupling
Code **L0026200**



Gearbox/ Speed (km/h):

7-speed (4 forward + 3 reverse) with 4.00-10" wheels

Speed (km/h)

1.20	1	1R	1.27
2.57	2	2R	2.66
4.17	3	3R	4.41
13.05	4		

Dimensions (mm)

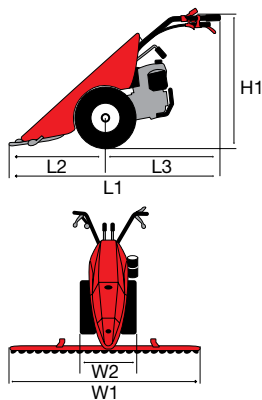

L1	1660 (1665)
L2	900 (950)
L3	760
H1	1255-405
W1	900-1600
W2	445-586

Transmission	with oil-bath gearbox
Clutch	dry multidisc
Handlebars	with vertical adjustment and anti-vibration device
Reverse gear	yes, with handlebar lever
Differential	yes
Brakes	yes
Power take-off	independent 973 rpm
Accessories installation	QuickFit supplied as standard
Weight	135 kg (with wheels, bar drive and cutter)



















Accessories



FC 30

Accessory		Optional accessory		
Tyred wheels				
 <p>Pair of tyred wheels 4.00x10" Fixed disc</p>	69200024	 <p>Pair of spacers W 50 mm</p>	69209094	
		 <p>Pair of spacers W 130 mm For fitting twin wheels</p>	69209097	
		 <p>Pair of snow chains</p>	L0021600	
 <p>Pair of tyred wheels 4.00x10" Adjustable disc</p>	69209004B	 <p>Pair of spacers W 50 mm</p>	69209094	
		 <p>Pair of spacers W 130 mm For fitting twin wheels</p>	69209097	
		 <p>Pair of tyre crampons 10"</p>	L0033800	
		 <p>Pair of snow chains</p>	L0021600	
 <p>Pair of tyred wheels 5.00x10" Adjustable disc</p>	69209003B	 <p>Pair of spacers W 50 mm (required for DIESEL engines)</p>	69209094	
		 <p>Pair of spacers W 150 mm For fitting twin wheels</p>	69209098	
		 <p>Pair of snow chains</p>	L0030200	
 <p>Pair of tyred wheels 18-9.50/8" Fixed disc</p>	69209104	 <p>Pair of spacers W 100 mm (required for assembly)</p>	69209103	
Steel wheels				
 <p>Pair of steel wheels Ø 480x100 mm</p>	69209067	 <p>Pair of width adjustment rings W 100 mm</p>	L0040100	

Accessories

Accessory	Optional accessory			
 <p>Oil-immersed drive</p>	69229025		0.95 m Complete central cutter plate Semi-fine teeth	69229084A*
			1.15 m Complete central cutter plate Semi-fine teeth	69229085A*
			1.27 m Complete central cutter plate Semi-fine teeth	69229086A*
			1.40 m Complete central cutter plate Semi-fine teeth	69229087A*
			1.60 m Complete central cutter plate Semi-fine teeth	69229093A*
			0.95 m Complete central cutter plate Special teeth Side protection discs	69229068A
			1.15 m Complete central cutter plate Special teeth Side protection discs	69229069A
			1.27 m Complete central cutter plate Special teeth Side protection discs	69229070A
			1.40 m Complete central cutter plate Special teeth Side protection discs	69229071A
			1.22 m Complete central cutter plate "UNIVERSAL" ESM (requires kit L0058900)	69229036
			1.42 m Complete central cutter plate "UNIVERSAL" ESM (requires kit L0058900)	69229021
			1.02 m Complete central cutter plate "KOMUNAL" ESM (requires kit L0058900)	L0066900
			1.22 m Complete central cutter plate "KOMUNAL" ESM (requires kit L0058900)	69229037
			1.42 m Complete central cutter plate "KOMUNAL" ESM (requires kit L0058900)	69229038
			Directional guides for semi-fine tooth cutter plate	69229098
			Ballast for mechanical drive	L0105500
	Ballast for oil-immersed drive	L0105700		

* (recommended for use in conjunction with directional guides 69229098).

Accessories



FC 30

Accessory		Optional accessory		
Front shovel				
 <p>Front shovel W 100x40 cm Quickfit coupling With horizontal and vertical adjustment</p>	69209065			
Snow thrower				
 <p>Turbine W 60 cm Two stages Adjustable ejector chute Quickfit coupling</p>	L0026200			
Front brush				
 <p>Brush W 100xØ 35 cm With horizontal and vertical adjustment Quickfit coupling</p>	L0094200			
Rotor type flail mower				
 <p>Flail mower W 65 cm 24 "Y" shaped knives Integral safety brake Adjustable flange Adjustable support roller PTO right-hand rotation Quickfit coupling</p>	L0091000			
Mover				
 <p>Mower W 75 cm Single blade Integral safety brake Adjustable and removable swivel wheels Adjustable lateral skids PTO right-hand rotation Quickfit coupling</p>	69209007			

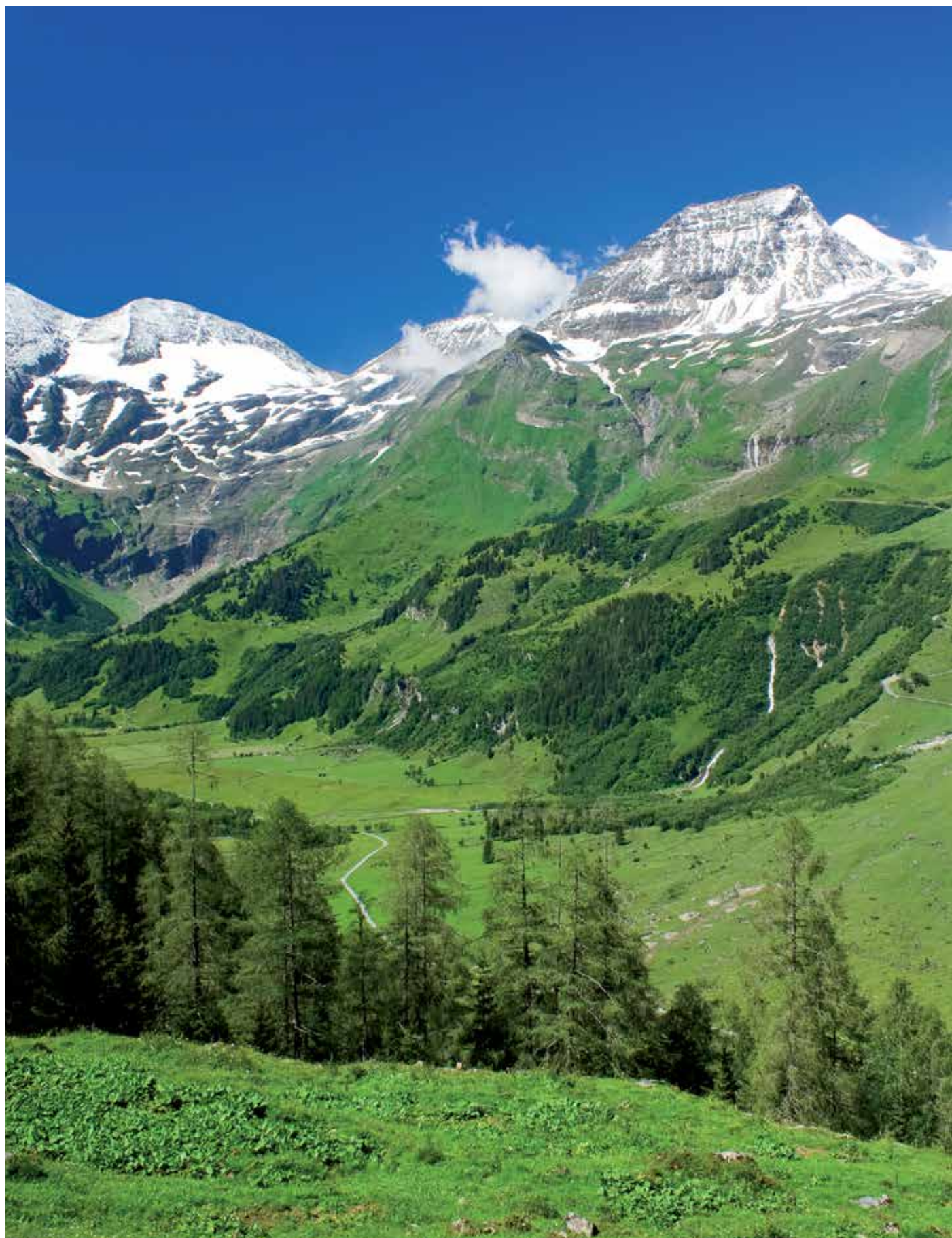

Tough, compact and easy to handle, for moving bulky and heavy loads effortlessly across all kinds of terrain.



Transporters

HOME



NTR 340



INTENSIVE



NTR 450



PROFESSIONAL



NTR 550



NTR 550 D



NTR 1750 D



TECHNICAL DATA



gearbox



load capacity



manual dumping



hydraulic dumping



liquid capacity

Transporter for home use

NTR 340



Designed for demanding home users needing to transport all types of material, such as firewood, fruit crates, and other bulky items, this machine is practical and easy to handle on all types of terrain.



Handlebar-mounted gear selection lever.



Speed selection control lever.



Manual dump with automatic locking system.

NTR 340

Power supply	Engine	Model	Displacement	Power	Starting	Code
gasoline	Emak	750 DOV	161 cm ³	3.8 HP	recoil start	68719041
gasoline	POWERED BY HONDA	GCVx 170 OHC	166 cm ³	4.4 HP	recoil start	68719049E5
gasoline	Emak	K 655 OHV	166 cm ³	3.9 HP	recoil start	68719045E5

Focus on accessories



High sides kit
Code **68722010**



Front shovel 85 cm
Code **69209071**



Gearbox/ Speed (km/h):

4-speed (2 forward + 2 reverse)

Speed (km/h)

1.60	1	1R	1.40
3.60	2	2R	3.40

Dimensions (mm)

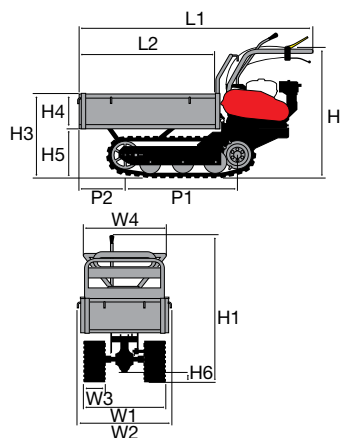

L1	1530-1665
L2	925-1060
H1	965
H2	885
H3	570
H4	240
H5	330
H6	65
W1	590
W2	603-983
W3	170
W4	520-900
P1	690
P2	415-550

Transmission	with oil-bath gearbox
Clutch	belt, with automatic disengagement when the control lever is released
Brakes	with automatic engagement when clutch is released
Load capacity	350 kg
Loading surface	telescoping
Dumping	manual
Dump angle	45°
Steering	with independent control releases and brakes
Minimum steering radius	70 cm
Crawler contact surface	58 cm length – 17 cm width
Power take-off	no
Weight	140 kg

Transporter for intensive use

NTR 450



Designed to meet the needs of demanding users, this model stands out for its manoeuvrability, ruggedness, and generous load capacity. It is also equipped with a power take-off to drive accessories.



Belt clutch with automatic disengagement when the control lever is released.



Steering with independently controlled releases and brakes.



Protected, expandable brakes for working in extreme conditions.

NTR 450

Power supply	Engine	Model	Displacement	Power	Starting	Code
gasoline	POWERED by HONDA	GX 160 OHV	163 cm ³	4.8 HP	recoil start	68729115E5

Focus on accessories



High sides kit
Code **68722003**



Front shovel 85 cm
Code **69209071**



Gearbox/ Speed (km/h):

4-speed (3 forward + 1 reverse)



Dimensions (mm)

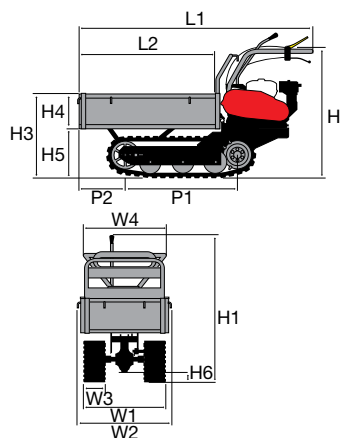

L1	1670
L2	925-1060
H1	1020
H2	900
H3	590
H4	240
H5	339
H6	70
W1	620
W2	643
W3	-
W4	560-940
P1	785
P2	330

Transmission	with oil-bath gearbox
Clutch	belt, with automatic disengagement when the control lever is released
Brakes	with automatic engagement when clutch is released
Load capacity	450 kg
Loading surface	telescoping
Dumping	manual
Dump angle	50°
Steering	with independent control releases and brakes
Minimum steering radius	70 cm
Crawler contact surface	60 cm length - 18 cm width
Power take-off	yes, independent 2100 rpm
Weight	180 kg

Professional transporter

NTR 550



This is a powerful professional machine, rugged and compact, and idea for use on all types of terrain. With high load capacity, this machine stands out for its versatility and the safety devices installed.



Independent PTO at 2100 rpm.



Steering with independently controlled releases and brakes.



Telescoping loading platform for transporting even the most bulky loads.

NTR 550

Power supply	Engine	Model	Displacement	Power	Starting	Code
gasoline	POWERED by HONDA	GX 160 OHV	163 cm ³	4.8 HP	recoil start	68729119E5

Focus on accessories



High sides kit
Code **68722004**



Front shovel 85 cm
Code **69209071**



Gearbox/ Speed (km/h):

6-speed (4 forward + 2 reverse)

Speed (km/h)

1.88	1	1R	1.86
3.16	2	2R	3.13
4.13	3		
7.00	4		

Dimensions (mm)

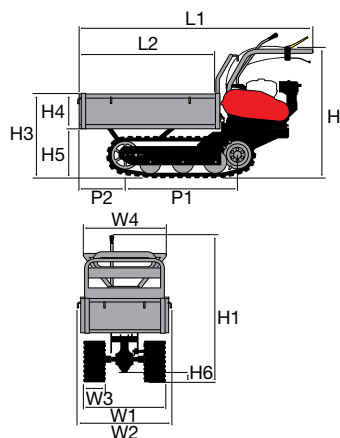

L1	1745
L2	1000-1180
H1	1020
H2	900
H3	590
H4	240
H5	339
H6	70
W1	620
W2	733
W3	-
W4	650-1100
P1	785
P2	405

Transmission	with oil-bath gearbox
Clutch	belt, with automatic disengagement when the control lever is released
Brakes	with automatic engagement when clutch is released
Load capacity	550 kg
Loading surface	telescoping
Dumping	manual
Dump angle	50°
Steering	with independent control releases and brakes
Minimum steering radius	70 cm
Crawler contact surface	60 cm length - 18 cm width
Power take-off	yes, independent 2100 rpm
Weight	200 kg

Professional transporter

— NTR 550 D



Professional model offering a combination of high power, easy handling and high load capacity. The transporter is ideal for applications in the agricultural and building sectors. Tipping is hydraulically operated to provide the maximum possible assistance for the operator during material handling activities.



Lever-operated hydraulic tipping control valve.



Steering with independently controlled releases and brakes.



Protected, expandable brakes for working in extreme conditions.

— NTR 550 D

Power supply	Engine	Model	Displacement	Power	Starting	Code
gasoline	POWERED by HONDA	GX 160 OHV	163 cm ³	4.8 HP	recoil start	68729129E5

Focus on accessories



High sides kit
Code **68722004**



Front shovel 85 cm
Code **69209071**



Gearbox/ Speed (km/h):

6-speed (4 forward + 2 reverse)

Speed (km/h)

1.88	1	1R	1.86
3.16	2	2R	3.13
4.13	3		
7.00	4		

Dimensions (mm)

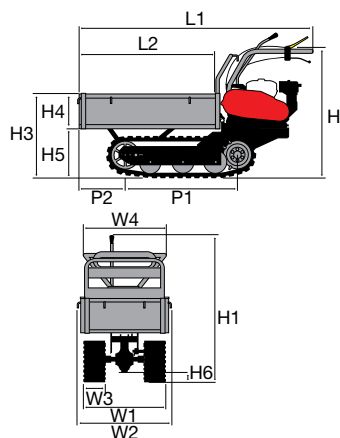

L1	1745
L2	1000-1180
H1	1020
H2	900
H3	590
H4	240
H5	339
H6	70
W1	620
W2	733
W3	-
W4	650-1100
P1	785
P2	405

Transmission	with oil-bath gearbox
Clutch	belt, with automatic disengagement when the control lever is released
Brakes	with automatic engagement when clutch is released
Load capacity	550 kg
Loading surface	telescoping
Dumping	hydraulic
Dump angle	50°
Steering	with independent control releases and brakes
Minimum steering radius	70 cm
Crawler contact surface	60 cm length - 18 cm width
Power take-off	yes, independent 2100 rpm
Weight	215 kg

Professional transporter

— NTR 1750 D



Designed for professional use, this is a dumper model machine with hydraulically operated load box tipping: ideal for transporting firewood, stone, sand and other building materials. Its increased dumping angle - 60° - meets the need for creating piles and mounds. Suited to all kinds of terrain, even on slopes, this transporter has a small steering radius, making it easy to handle.



Lever-operated hydraulic tipping control valve.



Dumper loading platform with counter-frame for 60° dump angle.



Crawler tracks made of hard rubber, width 180 mm: assure excellent grip on all types of terrain.

— NTR 1750 D

Power supply	Engine	Model	Displacement	Power	Starting	Code
gasoline	POWERED by HONDA	GX 160 OHV	163 cm ³	4.8 HP	recoil start	68729127E5

Focus on accessories



Front shovel 85 cm
Code **69209071**



Extendable loading deck
550 kg payload
Code **68722017**



Gearbox/ Speed (km/h):

6-speed (4 forward + 2 reverse)

Speed (km/h)

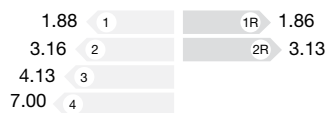

Dimensions (mm)

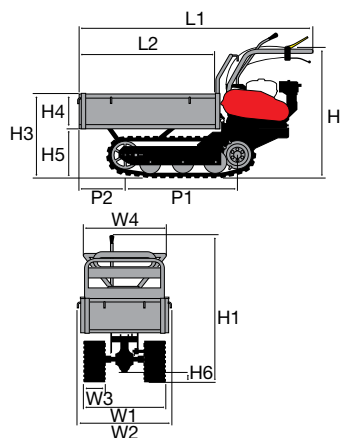

L1	1575
L2	915
H1	1020
H2	900
H3	515-725
H4	405
H5	320
H6	70
W1	622
W2	622
W3	-
W4	620
P1	785
P2	265

Transmission	with oil-bath gearbox
Clutch	belt, with automatic disengagement when the control lever is released
Brakes	with automatic engagement when clutch is released
Load capacity	550 kg - 175 L
Loading surface	fixed
Dumping	hydraulic
Dump angle	60°
Steering	with independent control releases and brakes
Minimum steering radius	70 cm
Crawler contact surface	60 cm length - 18 cm width
Power take-off	yes, independent 2100 rpm
Weight	215 kg

Data and illustrations published in the catalogue are not binding where specifications of materials are concerned, given that these will always be subject to technical improvement. Technical specifications given in the catalogue are subject to change without notice, as also are directions relating to general use of the equipment.

Engine power data refers to the values declared by each manufacturer. These values are calculated in accordance with specific measurement standards (such as SAE J1940, SAE J1349, ISO 1585) and may be modified without prior notice.

Certain items are not available in all countries, or are available only on request.





Subject to modifications. Some models are available for certain markets only. - Cod. 3285002L - 2019



It's an **Emak S.p.A.** trademark
42011 Bagnolo in Piano (RE) Italy
www.mynibbi.com

